

1. BUTTON CLAMP MECHANISM COMPONENTS

ボタンツマミ関係

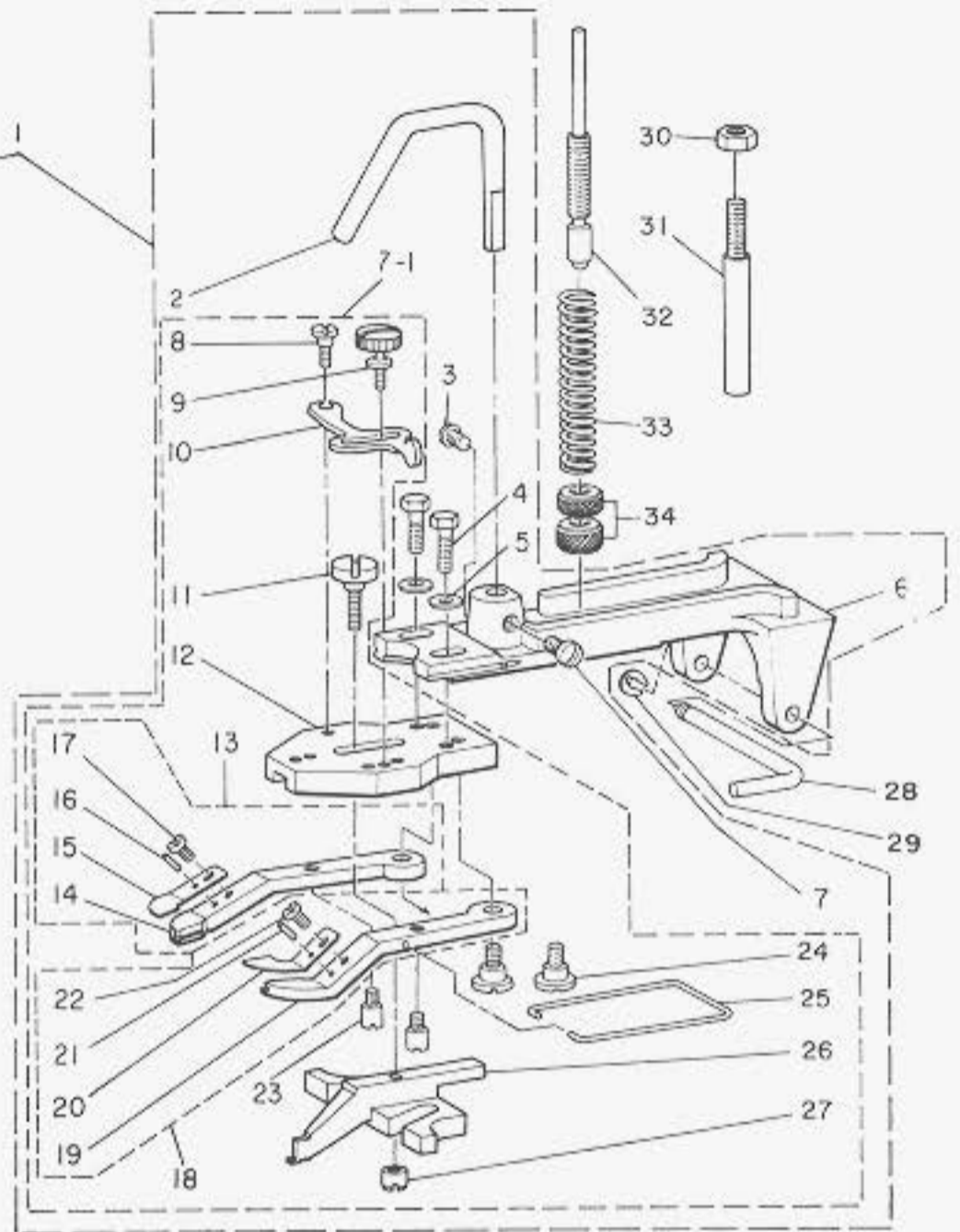

Ref. No.	Note	Part No.	Description	E.C.	品名	Amt. Req.
	注記	品番		変更年月		数量
1		B2547-372-0B0	Flat button clamp asm.		平ボタンツマミ装置 (組)	1
2		B2546-372-000	Button clamp lifting hook		ツマミ装置引上げフック	(1)
3		SS-8150510-TP	Screw (B) 15/64-28 L=4.7	D.2/85	SS-7150940-SP	-
		SS-7150940-SP	Screw 15/64-28 L=9.0	A.2/85	ツマミ装置引上げフック止ネジ	(1)
4		SS-9621413-SP	Screw 3/16-32 L=13.5		ツマミ足取付台止ネジ	(2)
5		WP-0501016-SD	Washer 5.0x10.5x1.0		ツマミ足取付台止ネジ座金	(2)
6		B2542-372-000	Button clamp holder		ツマミ装置取付台	(1)
7		SS-7150940-SP	Screw (A) 15/64-28 L=9.0		ツマミ装置引上げフック止ネジ (A)	(1)
7-1	◇	B2547-372-0C0	Button clamp jaw lever holder asm.	A.2/86	ボタンツマミ足取付台 (組)	(1)
8		SD-0550181-SP	Hinge screw (B) D=5.50 H=1.8		開キレバー止ネジ (B)	(1)
9		B2549-372-000	Clamp screw (A)		開キレバー止ネジ (A)	(1)
10		B2548-372-000	Button clamp stop lever		ツマミ足開キレバー	(1)
11		SD-0550301-SP	Hinge screw (A) D=5.50 H=3.0		ボタンガイド足止ネジ (A)	(1)
12		B2547-372-000	Button clamp jaw lever holder		ボタンツマミ足取付台	(1)
13		B2555-372-0A0	Button clamp jaw lever (LEFT) asm.		ボタンツマミ足 (左) (組)	(1)
14		B2555-372-000	Button clamp jaw lever (LEFT)		ボタンツマミ足 (左)	(1)
15		B2556-372-000	Button clamp plate spring (LEFT)		ボタンツマミ板バネ (左)	(1)
16		B2559-372-000	... Guide pin		ボタンツマミ板バネガイドピン	(1)
17		SS-7090520-TP	Screw 9/64-40 L=4.5	D.6/85	SS-7090410-SP	-
		SS-7090410-SP	Screw 9/64-40 L=3.5	A.6/85	ツマミ足板バネ止ネジ	(1)
18		B2557-372-0A0	Button clamp jaw lever (RIGHT) asm.		ボタンツマミ足 (右) (組)	(1)
19		B2557-372-000	Button clamp jaw lever (RIGHT)		ボタンツマミ足 (右)	(1)
20		B2558-372-000	Button clamp plate spring (RIGHT)		ボタンツマミ板バネ (右)	(1)
21		B2559-372-000	... Guide pin		ボタンツマミ板バネガイドピン	(1)
22		SS-7090520-TP	Screw 9/64-40 L=4.5	D.6/85	SS-7090410-SP	-
		SS-7090410-SP	Screw 9/64-40 L=3.5	A.6/85	ツマミ足板バネ止ネジ	(1)
23		B2560-372-000	Button clamp stop pin		ツマミ足開キピン	(2)
24		SD-0640391-TP	Hinge screw D=6.35 H=3.9		ボタンツマミ足止ネジ	(2)
25		B2561-372-000	Button clamp spring		ボタンツマミ足バネ	(1)
26		B2552-372-000	Button clamp slide guide		ボタンガイド足	(1)
27		B2553-372-000	... Screw (B)		ボタンガイド足止ネジ (B)	(1)
28		B2540-372-000	Button clamp installing stud		ツマミ装置取付軸	1
29		B2541-372-000	... Snap ring		ツマミ装置取付用スナップリング	1
30		NS-6160520-SP	Nut 1/4-24		ツマミ装置ストッパーピンナット	1
31		B2543-372-000	Button clamp stopper pin		ツマミ装置ストッパーピン	1
32		B2544-372-000	... Pressure adjusting bar		押エ圧力調節棒	1
33		B2545-372-000	... Spring		押エ調節バネ	1
34		B3125-012-000	... Nut		押エ調節ナット	2
35	◇03	B3130-372-000	... From the library of: Superior Sewing Machine & Supply LLC		押エ調節ナット	1

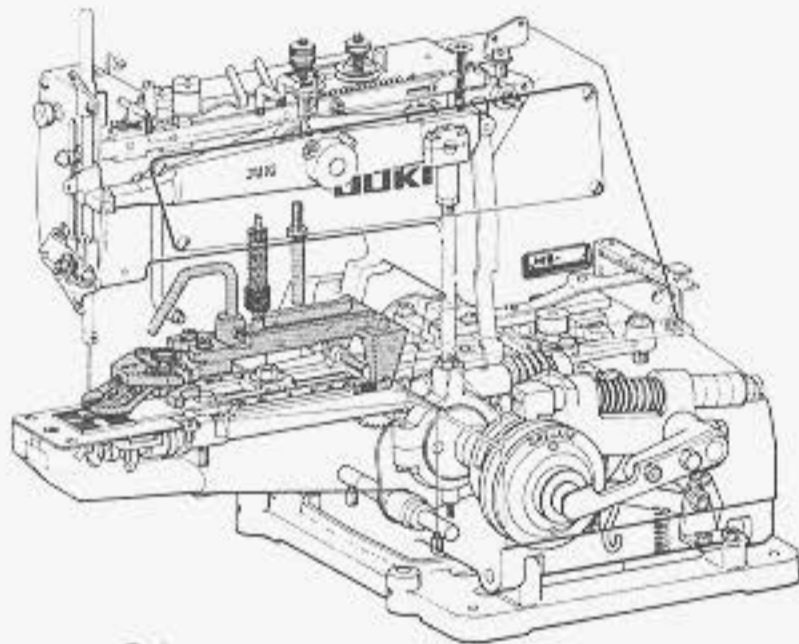
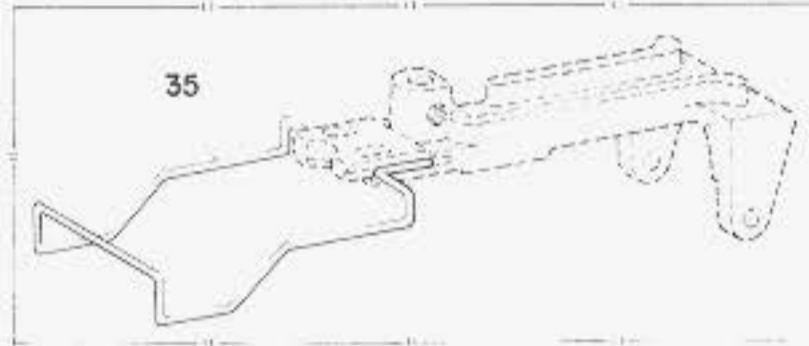
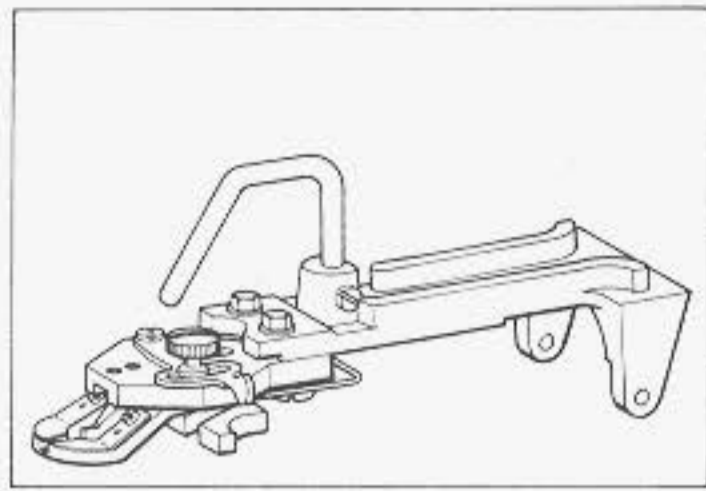
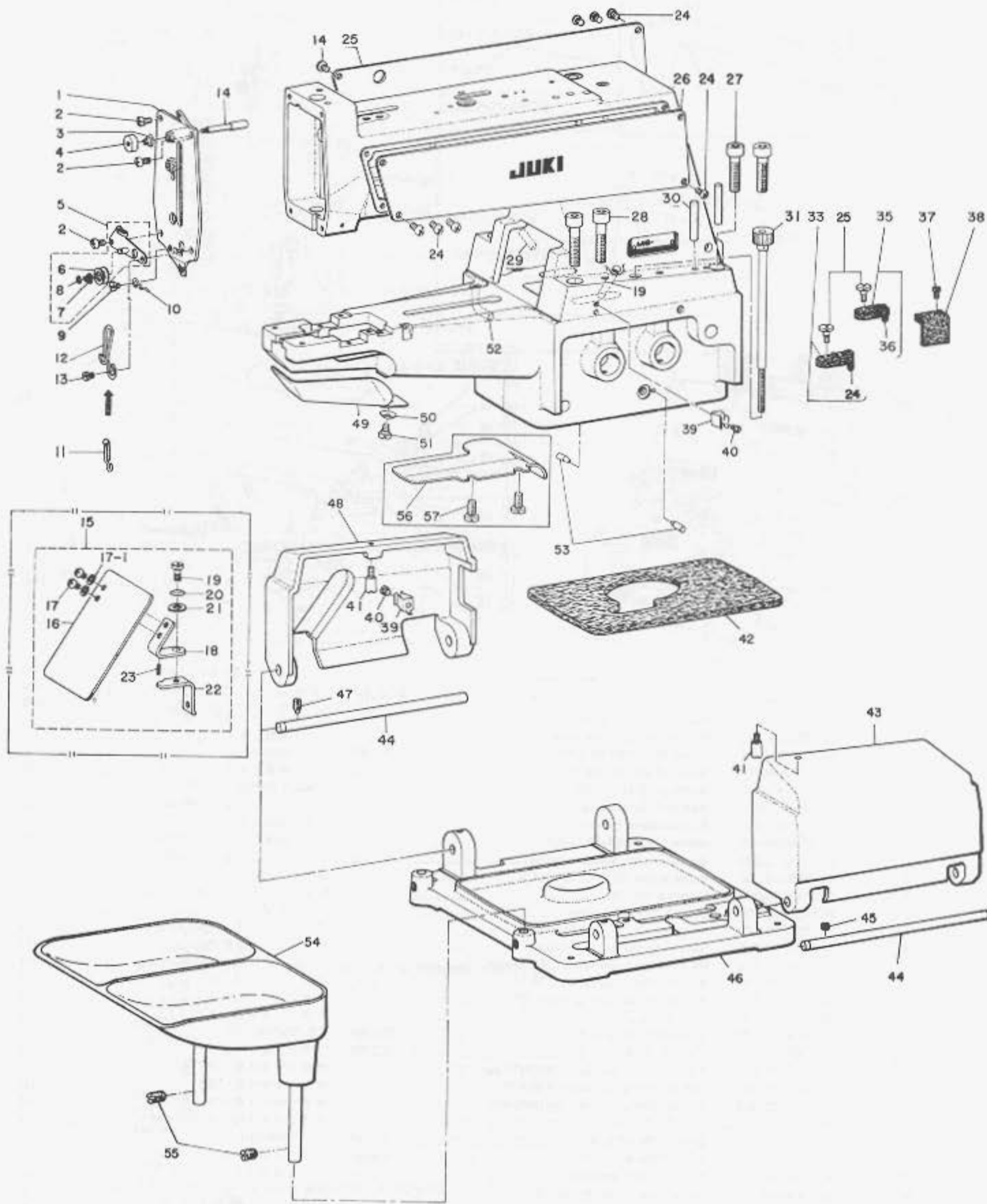

2. ARM & MISCELLANEOUS COVERS COMPONENTS

アームベット関係

Ref. No.	Note	Part No.	Description	E.C.	品名	Amt. Req.
	注記	品番		変更年月		数量
1		B3101-372-0A0	Machine arm front cover asm.		面板 (組)	1
2		SS-5110810-SP	Screw 11/64-40 L=8.0	D.11/82	SS-4110815-SP	-
		SS-4110815-SP	Screw 11/64-40 L=8.0	A.11/82	ナベネジ 11/64-40 L=8	3
3		B3149-123-A00	Nipper releasing plunger spring		ニッパ-糸ユルメピンバネ	1
4		B3103-372-000	Knurled thumb nut		ニッパ-糸ユルメ棒ナット	1
5		B3109-372-0A0	Thread tension guide No.3 asm.		第3糸調子皿糸案内 (組)	1
6		B3148-123-000	Thread tension guide No.3 disc		第3糸調子皿	(2)
7		B3149-123-A00	Thread tension guide No. 3 spring	D.9/79	B3110-372-000	-
		B3110-372-000	Thread tension guide No. 3 spring	A.9/79	第3糸調子バネ	(1)
8		RE-0300000-K0	Snap ring		第3糸調子エリリング	(1)
9		SS-7110340-SP	Screw 11/64-40 L=3.2		第4糸案内止ネジ	1
10		B3108-372-000	Thread guide No.4		第4糸案内	1
11	001	B3107-372-000	Thread guide No.3	D.9/75	B3107-373-000	-
12		B3107-373-000	Thread guide No.3		第3糸案内	1
13		SS-5110810-SP	Screw 11/64-40 L=8.0		第3糸案内止ネジ	1
14		B3104-372-000	Nipper releasing plunger		ニッパ-糸ユルメ棒	1
15	003	B3120-372-0A0	Safety plate asm.		安全プレート (組)	1
16	003	B3120-372-000	Safety plate		安全プレート	(1)
17	003	SS-7110740-TL	Screw 11/64-40 L=7.0	D.9/79	SS-7110740-TP	-
	003	SS-7110740-TP	Screw 11/64-40 L=7.0	D.11/82	SS-4110715-SP	-
	003	SS-4110715-SP	Screw 11/64-40 L=7.0	A.11/82	ナベネジ 11/64-40 L=7	(2)
17-1	003	WP-0450801-SD	Washer 4.5 x 10 x 0.8	A.4/84	ワガネ 4.5x10x0.8	(2)
18	003	B3121-372-000	Installing plate		安全プレート取付板	(1)
19	003	SD-0600401-SD	Hinge screw D=6.00 H=4.0		安全プレート用段ネジ	(1)
20	003	B3125-155-000	Spring washer		安全プレート用バネ座金	(1)
21	003	WP-0650876-SD	Washer 6.5 x 13.0 x 0.8		安全プレート用座金	(1)
22	003	B3122-372-000	Installing base		安全プレート取付台	(1)
23	003	B3123-372-000	Stopper pin	D.3/83	PS-0200062-KH	-
	003	PS-0200062-KH	Pin	A.3/83	ピン	(1)
24		SS-5110810-SP	Screw 11/64-40 L=8.0	D.11/82	SS-4110815-SP	-
		SS-4110815-SP	Screw 11/64-40 L=8.0	A.11/82	ナベネジ 11/64-40 L=8	8
25		B1113-372-000	Machine arm side cover (LEFT)		側面板 (左)	1
26		B1112-372-000	Machine arm side cover (RIGHT)		側面板 (右)	1
27		SM-6083042-CP	Connecting screw (A) M8 x 1.25 L=30	D.4/76	SM-6083042-CH	-
		SM-6083042-CH	Connecting screw (A) M8 x 1.25 L=30	A.4/76	アームベット結合ネジ (A)	2
28		SM-6083542-CP	Connecting screw (B) M8 x 1.25 L=35	D.4/76	SM-6083542-CH	-
		SM-6083542-CH	Connecting screw (B) M8 x 1.25 L=35	A.4/76	アームベット結合ネジ (B)	2
29		B3505-372-000	Oil supply tube	D.8/79	PS-0600241-00	-
		PS-0600241-00	Oil supply tube	A.8/79	ボタン付用給油パイプ	2
30		B1105-372-000	Guide pin		アームベット結合ガイドピン	2
31		B1106-372-0A0	Set screw asm.		アームベット取付ネジ (組)	1
32		SD-0500451-SD	Hinge screw D=5.00 H=4.5	D.7/76	フェルト止ネジ	-
33		B3501-372-0A0	Oil felt (LARGE) asm.		油溜フェルト (大)(組)	1
34		CQ-3030000-00	Oil wick		ボタン付用油心	(0.1)
35		B3502-372-0A0	Oil felt (SMALL) asm.		油溜フェルト (小)(組)	1
36		CQ-3030000-00	Oil wick		ボタン付用油心	(0.1)
37		SS-7110820-SP	Screw 11/64-40 L=7.5	D.10/76	SS-7110840-SP	-
		SS-7110840-SP	Screw 11/64-40 L=7.8	A.10/76	ウォーム用フェルト止ネジ	1
38		B3503-372-000	Felt		ウォーム用フェルト	1
39		B1111-372-000	Stop motion & pulley cover spring		側面カバーバネ	2
40		SS-7090520-SP	Screw 9/64-40 L=4.5		側面カバーバネ止ネジ	2
41		B1120-372-000	Stud		側面カバーバネ軸	2
42		B1104-372-A00	Oil drip felt		吸油フェルト	1
43		B1109-372-000	Stop motion & pulley cover (RIGHT)		側面カバー (右)	1
44		B1110-372-000	Stud		側面カバー軸	2
45		SS-8150410-SP	Screw (RIGHT) 15/64-28 L=4.0		側面カバー軸止ネジ (右)	1
46		B1103-372-000	Machine sub base		ベット取付台	1
47		SS-8151150-SP	Screw (LEFT) 15/64-28 L=10.5	M.1/78	側面カバー軸止ネジ (左)	1
48		B1108-372-000	Stop motion & pulley cover (LEFT)		側面カバー (左)	1
49		B1118-372-000	Looper cover		ルーバーカバー	1
50		WS-0650389-KP	Washer 6.5 x 14.0 x 17		ルーバーカバー止ネジ座金	1
51		SD-0600271-SP	Hinge screw D=6.00 H=2.7		ルーバーカバー止ネジ	1
52		B3506-372-000	Oil supply tube	D.8/79	油槽用給油パイプ	-
53		B2504-372-000	Feed cam position indicating pin		送りカム位置決め指針	2
54		B8210-372-0A0	Button tray asm.		ボタン受皿 (組)	1
55		SS-8150710-SP	Screw 15/64-28 L=7.0		ボタン受皿支柱止ネジ	2
56	002	B1119-373-000	Bed oil shield	A.8/78	ベット油防板	1
57	002	SS-7110840-SP	Screw 11/64-40 L=7.8	A.8/78	ベット油防板止ネジ	2

Note (注記) 001 For MB-372 MB-372用
 002 For MB-373 MB-373用
 003 Special order parts for MB-372, MB-373 MB-372、MB-373用特別注文部品

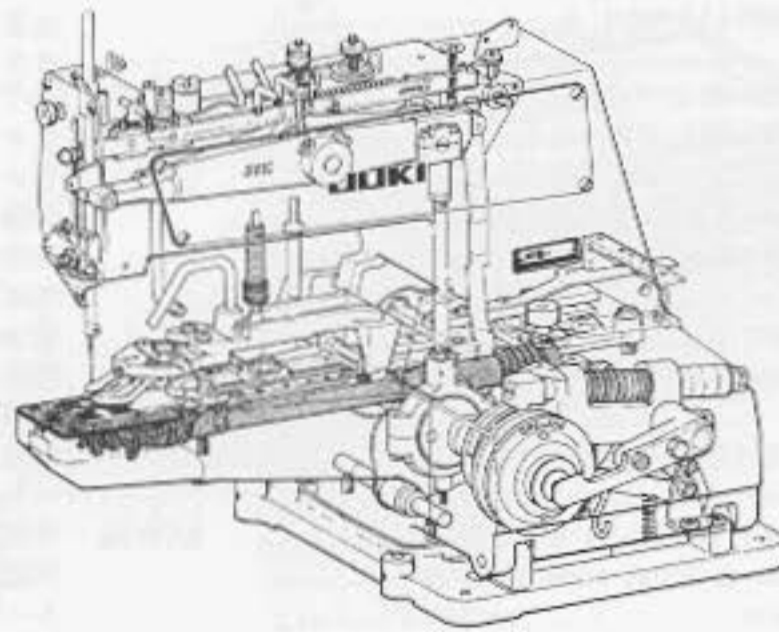
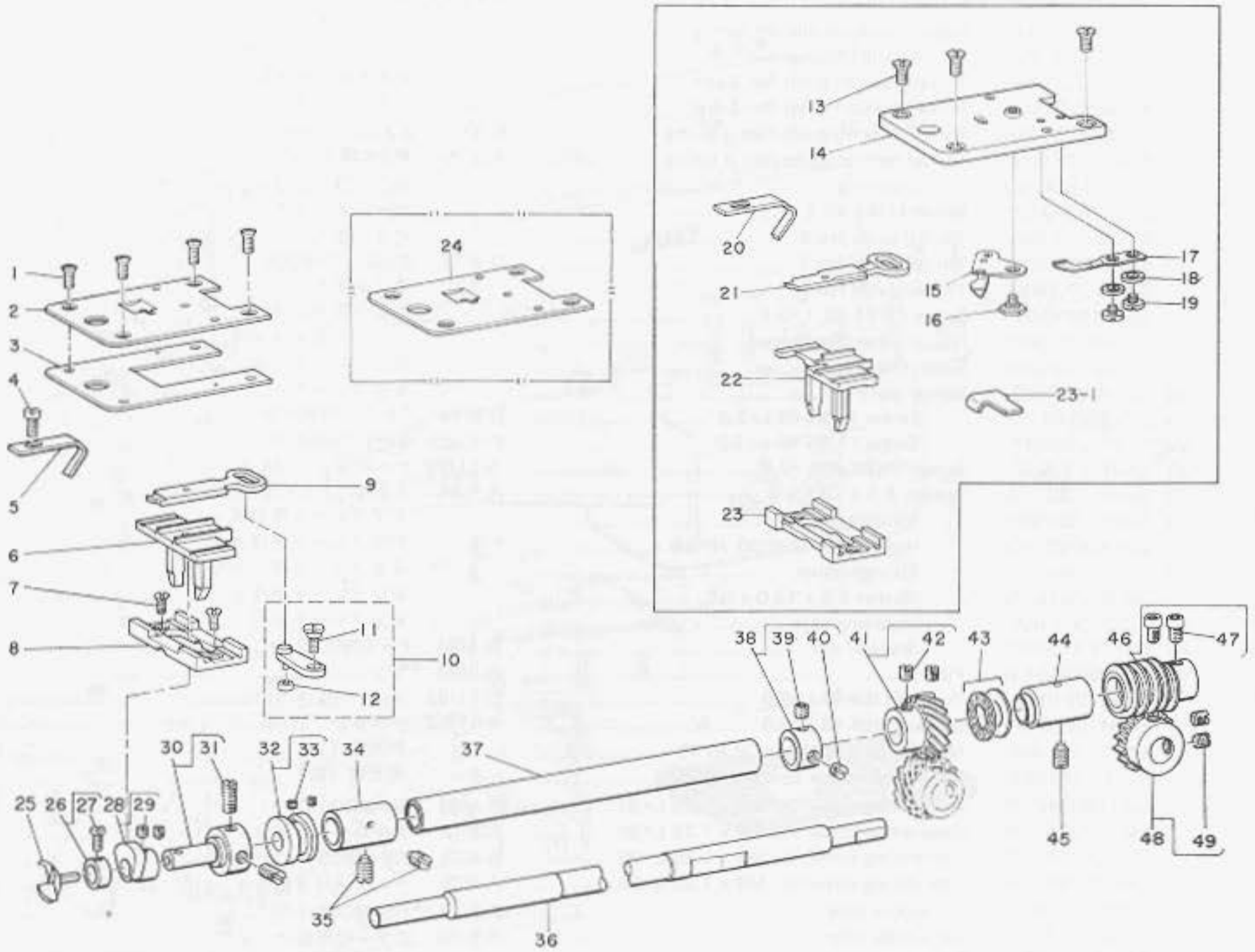

3. LOOPER SHAFT MECHANISM COMPONENTS

ルーパー軸関係

Ref. No.	Note	Part No.	Description	E.C. 変更年月	品名	Amt. Req. 数量
	注記	品番				
1	◇01	SS-2110920-TP	Screw 11/64-40 L=8.5		針板止ネジ	4
2	◇01	B1241-372-000	Throat plate		針板	1
3	◇01	B1240-372-000	Spacer plate		針板下板	1
4		SS-7110710-SP	Screw 11/64-40 L=7.0		針ガイド止ネジ	1
5	◇01	B1242-372-000	Needle guide		針ガイド	1
6	◇01	B1236-372-000	Positioning finger yoke slide		糸寄せ支エ	1
7		SS-1110710-SP	Screw 11/64-40 L=7.0		糸寄せ支エ台止ネジ	2
8	◇01	B1235-372-000	Yoke slide insert		糸寄せ支エ台	1
9	◇01	B1237-372-000	Yoke slide		糸寄せ	1
10		B1230-372-0A0	Loop positioning finger asm.		糸寄せ前後腕(組)	1
11		SD-0640241-SP	Hinge screw D=6.35 H=2.4		糸寄せ前後腕止ネジ	1
12		B1232-372-000	... Lever roll		糸寄せカムコロ	1
13	◇02	SS-2110920-TP	Screw 11/64-40 L=8.5		針板止ネジ	3
14	◇02	B1241-373-0A0	Throat plate asm.	D.1/76	B1241-373-000	-
	◇02	B1241-373-000	Throat plate	A.1/76	針板	1
15	◇02	B2406-373-0A0	Moving knife asm.		動メス(組)	1
16	◇02	SD-0600095-TH	Hinge screw D=6.00 H=0.85		動メス段ネジ	1
17	◇02	B2410-373-000	Fixed knife		固定メス	1
18	◇02	WP-0370316-SD	Washer 3.7 x 8.0 x 0.3		固定メス止ネジ座金	2
19	◇02	SS-7080310-SP	Screw 1/8-44 L=3.0		固定メス止ネジ	2
20	◇02	B1242-373-000	Needle guide		針ガイド	1
21	◇02	B1237-373-000	Yoke slide		糸寄せ	1
22	◇02	B1236-373-000	Positioning finger yoke slide		糸寄せ支エ	1
23	◇02	B1235-373-000	Yoke slide insert		糸寄せ支エ台	1
23-1	◇02	B2414-373-000	Moving knife positioning gauge	A.12/77	動メス位置合せゲージ	1
24	◇04	B1241-372-B00	Throat plate, thick		太針用針板	1
25		B1239-372-000	Looper		ルーパー	1
26		CS-079061A-TH	... Collar asm.	D.7/85	CS-079072A-TH	-
		CS-079072A-TH	... Collar asm.	A.7/85	ルーパー支エリング(組)	1
27		SS-7090620-TP	Screw 9/64-40 L=6.1		ルーパー止ネジ	(1)
28		B1234-372-0A0	Loop positioning finger cam asm.		糸寄せ三角カム(組)	1
29		SS-8110410-TP	Screw 11/64-40 L=3.5		糸寄せ三角カム止ネジ	(2)
30		B1233-372-0A0	Cam & looper sleeve asm.		ルーパー取付軸(組)	1
31		SS-8150410-TP	Screw 15/64-28 L=4.0		ルーパー取付軸止ネジ	(2)
32		B1228-372-0A0	Loop positioning finger cam asm.		糸寄せカム(組)	1
33		SS-8110310-SP	Screw 11/64-40 L=2.8		糸寄せカム止ネジ	(2)
34		B1227-372-000	Looper shaft bushing, front		ルーパー軸前メタル	1
35		SS-8151150-SP	Screw 15/64-28 L=10.5		ルーパー軸前メタル止ネジ	2
36		B1219-372-000	Looper shaft		ルーパー軸	1
37		B1226-372-000	... Tube	D.5/79	ルーパー軸パイプ	-
38		CS-111101B-SH	... Collar asm.		ルーパー軸スラスト受リング(組)	1
39		SS-8660512-TP	Screw 1/4-40 L=5.0		ルーパー軸スラスト受リング止ネジ(A)	(1)
40		SS-8660612-TP	Screw 1/4-40 L=6.0		SS-8660330-SP	(1)
		SS-8660330-SP	Screw 1/4-40 L=3.0	A.5/79	ルーパー軸スラスト受リング止ネジ(B)	(1)
41		B1224-372-0A0	Looper shaft driven gear (B) asm.		ネジ歯車(B)(組)	1
42		SS-8660612-TP	Screw 1/4-40 L=6.0		ネジ歯車(B)止ネジ	(2)
43		B1215-372-A00	Looper shaft thrust ball bearing		ルーパー軸スラストベアリング	1
44		B1222-372-000	Looper shaft bushing, rear		ルーパー軸後メタル	1
45		SS-8151150-SP	Screw 15/64-28 L=10.5		ルーパー軸後メタル止ネジ	1
46		B1221-372-0A0	Driving worm gear asm.		ウォーム(組)	1
47		SS-8660712-TP	Screw 1/4-40 L=7.0		ウォーム止ネジ	(2)
48		B1220-372-0A0	Cam shaft driven gear asm.		ウォーム歯車(組)	1
49		SS-8660612-TP	Screw 1/4-40 L=6.0		ウォーム歯車止ネジ	(2)

Note (注記) ◇01 For MB-372 MB-372 用
 ◇02 For MB-373 MB-373 用
 ◇04 Special order part for MB-372 MB-372 用特別注文部品

4. NIPPER & THREAD TENSION PARTS COMPONENTS

糸調子、ニッパー関係

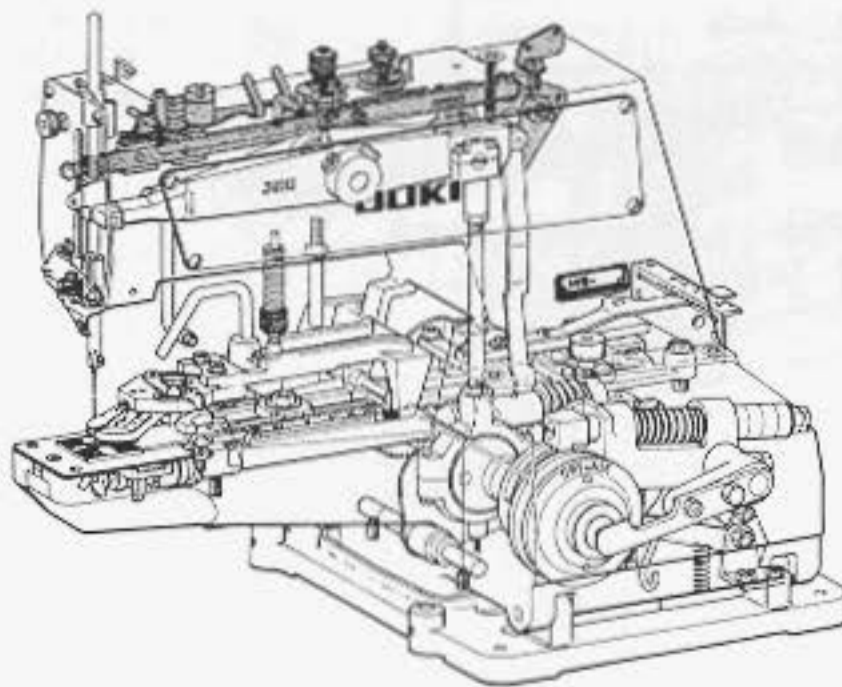
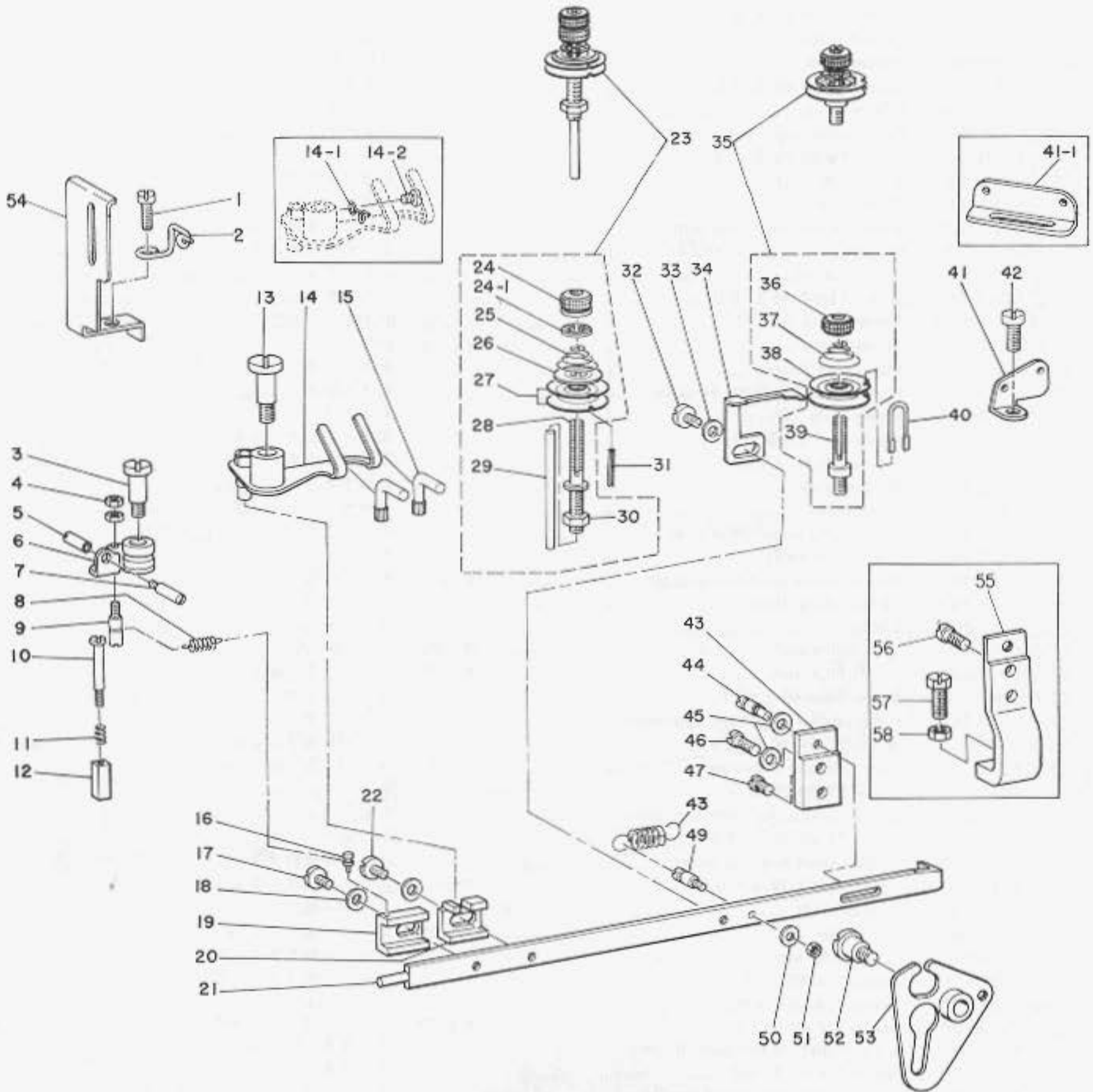

4. NIPPER & THREAD TENSION PARTS COMPONENTS

糸調子、ニッパー関係

Ref. No.	Note	Part No.	Description	E.C.	品名	Amt. Req.
	注記	品番		変更年月		数量
1		SS-3150710-TP	Screw 15/64-28 L=6.5	D.5/77	SS-7151210-SP	—
		SS-7151210-SP	Screw 15/64-28 L=12.0	A.5/77	第2糸案内止ネジ	1
2		B2038-372-000	Thread guide No.2		第2糸案内	1
3		SD-0791271-SP	Hinge screw D=7.94 H=12.7		ニッパー段ネジ	1
4		NS-6080210-SP	Nut 1/8=44		ニッパー引張りバネ軸ナット	2
5		B2035-372-000	Nut		ニッパー糸ユルメピンナット	1
6		B2031-372-0A0	Thread nipper asm.		ニッパー(組)	1
7		B2034-372-000	Thread releasing pin		ニッパー糸ユルメピン	1
8		B2037-372-000	Nipper bar block spring		ニッパー引張りバネ	1
9		B2036-372-000	... Stud		ニッパー引張りバネ軸	1
10		SD-0402001-SP	Hinge screw D=4.00 H=20.0	D.9/81	SD-0402001-TP	—
		SD-0402001-TP	Hinge screw D=4.00 H=20.0	A.9/81	ニッパー角駒軸	1
11		B2029-372-000	Nipper block spring		ニッパー角駒バネ	1
12		B2028-372-000	Nipper block		ニッパー角駒	1
13		SD-0791501-SP	Hinge screw D=7.94 H=15.0		糸調節レバー段ネジ	1
14		B2025-372-0A0	Thread pull-off lever asm.	D.1/81	B2025-372-0B0	—
		B2025-372-0B0	Thread pull-off lever asm.	A.1/81	糸調節レバー(組)	1
14-1	002	B2040-373-000	... Thread guide	A.8/78	糸調節レバー糸案内	1
14-2	002	SS-7090510-SP	Screw 9/64-40 L=4.6	A.8/78	糸調節レバー糸案内止ネジ	1
15		B2024-372-000	L shaped thread guide		L型糸案内	2
16		B2012-372-000	Nipper bar block spring pin		ニッパー引張りバネピン	1
17		SS-6120930-TP	Screw 3/16-28 L=9.0		ニッパー揺動駒止ネジ	1
18		WP-0501016-SD	Washer 5.0 x 10.5 x 1.0		揺動駒止ネジ座金	2
19		B2011-372-000	Nipper bar block		ニッパー揺動駒	1
20		B2010-372-000	Nipper bar block, rear		糸調子レバー揺動駒	1
21		B2004-372-000	Nipper bar		糸調子調節桿	1
22		SS-6120930-SP	Screw 3/16-28 L=9.0		糸調子レバー揺動駒止ネジ	1
23		B2019-372-0A0	Tension post No.2 asm.		第2糸調子棒(組)	1
24		B3125-012-000	... Nut	D.6/79	B3116-125-000	—
		B3116-125-000	... Nut	A.6/79	第2糸調子ナット	(1)
24-1		B3120-125-000	... Stopper	A.6/79	糸調子匡回転止	(1)
25		B3114-232-000	... Spring No. 2		第2糸調子バネ	(1)
26		B3132-012-000	... Lifting washer		糸調子皿押エ	(1)
27		B2016-372-000	... Disc		糸調子皿	(2)
28		B2019-372-000	... Post No. 2		第2糸調子棒	(1)
29		B2020-372-000	... Release pin		調子皿浮シ棒	(1)
30		NS-6160520-SP	Nut 1/4-24		第2糸調子棒調節止ナット	(1)
31		B2023-372-000	Tension disc pin No. 2	D.12/79	PS-0200142-K0	—
	☆	PS-0200142-K0	Tension disc pin No. 2	D.2/88	PS-0200162-KH	—
32	☆	PS-0200162-KH	Tension disc pin No. 2	A.2/88	第2糸調子皿案内棒	1
32		SS-6120930-SP	Screw 3/16-28 L=9.0		調子皿浮シ板止ネジ	1
33		WP-0501016-SD	Washer 5.0 x 10.5 x 1.0		調子皿浮シ板止ネジ座金	1
34		B2009-372-000	Tension releasing lever		調子皿浮シ板	1
35		B2015-372-0A0	Tension post No.1 asm.		第1糸調子棒(組)	1
36		B2314-019-000	... Nut	D.7/75	B3125-012-000	—
		B3125-012-000	... Nut	A.7/75	第1糸調子ナット	(1)
37		B2017-372-000	... Spring No.1		第1糸調子バネ	(1)
38		B2016-372-000	... Disc		糸調子皿	(2)
39		B2015-372-000	... Post No.1		第1糸調子棒	(1)
40		B2014-372-000	Tension disc pin No.1		第1糸調子皿案内棒	1
41	001	B1111-232-000	Thread guide No. 1		第1糸案内	1
41-1	002	B2039-373-000	Thread guide No. 1	A.8/78	第1糸案内	1
42		SS-7151210-SP	Screw 15/64-28 L=12.0		第1糸案内止ネジ	1
43	001	B2005-372-000	Nipper bar bearing block		糸調子調節桿案内台	1
44		B2006-372-000	... Adjusting screw		糸調子調節桿案内軸	1
45		WP-0480856-SP	Washer 4.8 x 8.4 x 0.8		糸調子調節桿案内軸座金	2
46	001	SS-6121610-SP	Screw (A) 3/16-28 L=15.5	D.8/80	SS-6121610-TP	—
	001	SS-6121610-TP	Screw (A) 3/16-28 L=15.5	A.8/80	糸調子調節桿案内台止ネジ(A)	1
47		SS-6121050-SP	Screw (B) 3/16-28 L=9.5		糸調子調節桿案内台止ネジ(B)	1
48		B2008-372-000	Nipper bar spring		糸調子調節桿引張りバネ	1
49		B2007-372-000	... Screw		糸調子調節桿引張りバネ止ネジ	1
50		WP-0371016-SD	Washer 3.7 x 8.0 x 1.0		糸調子調節桿引張りバネ止ネジ座金	1
51		NS-6080340-SP	Nut 1/8-44		糸調子調節桿引張りバネ止ネジナット	1
52		SD-0790802-SP	Hinge screw D=7.94 H=8.0		三角板段ネジ	1
53		B2001-372-0A0	Nipper bar actuating lever asm.		三角板(組)	1
54		B1421-372-000	Needle bar guard	A.5/77	針棒カバー	1
55	002	B2005-373-000	Nipper bar bearing block	A.12/77	糸調子調節桿案内台	1
56	002	SS-6121610-TP	Screw (A) 3/16-28 L=15.5	A.12/77	糸調子調節桿案内台止ネジ(A)	1
57	002	SS-9151420-TP	Screw 15/64-28 L=14.0	A.12/77	調節ネジ	1
58	002	NS-6150310-SP	Nut 15/64-28	A.12/77	調節ネジナット	1

5. FEED PLATE COMPONENTS

送り関係

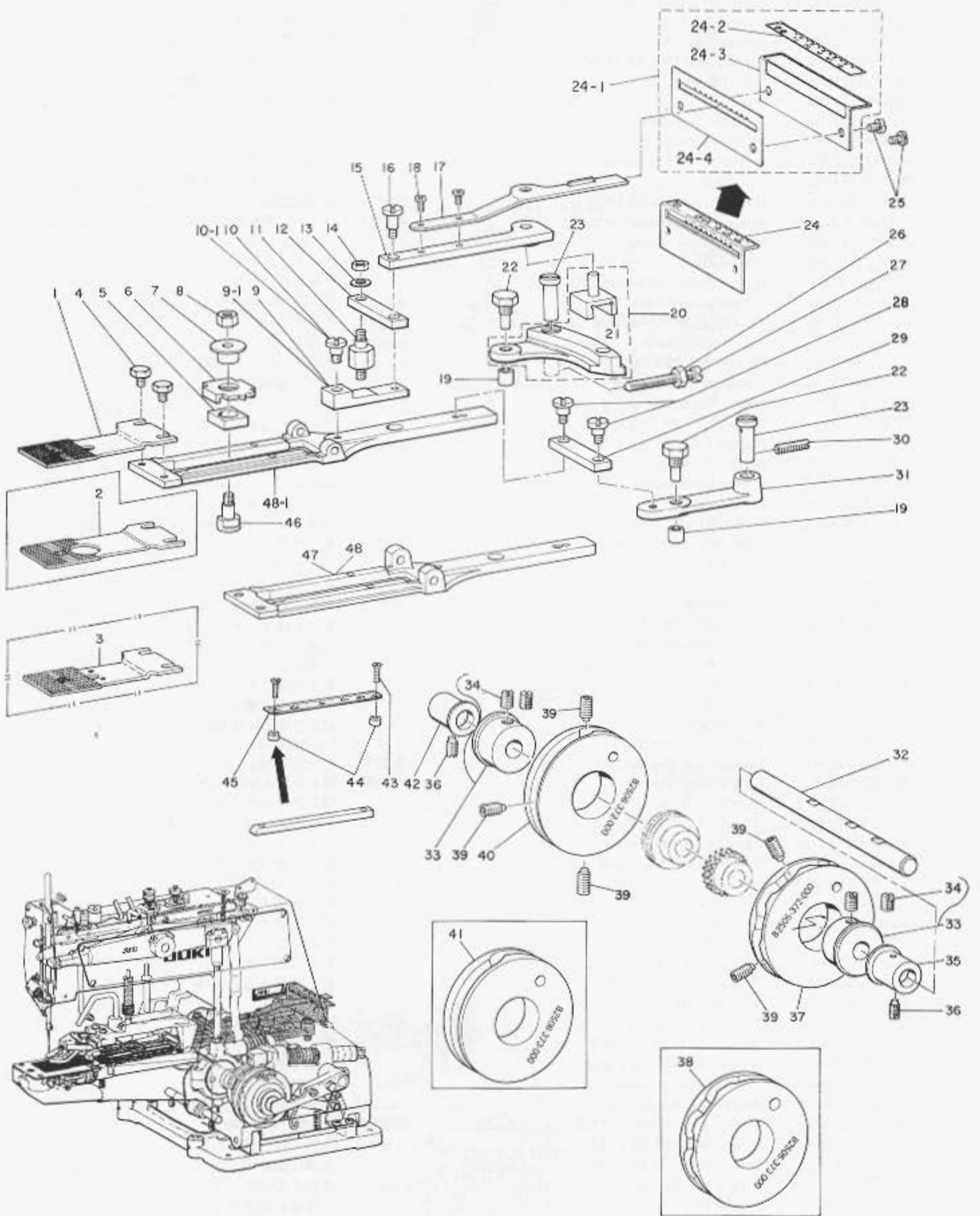

5. FEED PLATE COMPONENTS

送り関係

Ref. No.	Note	Part No.	Description	E.C.	品名	Amt. Req.
	注記	品番		変更年月		数量
1	◇01	B2529-372-000	Feed plate, small button		小ボタン用布押エ下板	1
2	◇02	B2529-373-000	Feed plate, small button		小ボタン用布押エ下板	1
3	◇04	B2529-372-C00	Feed plate, small button		小ボタン用布押エ下板	1
4		SS-9120643-TP	Screw 3/16-28 L=6.0		小ボタン用布押エ下板止ネジ	2
5		B2524-372-000	Indicator pin bearing block		横送り指針軸駒	1
6		B2525-372-000	Crosswise feed indicator		横送り指針	1
7		B2526-372-000	. . . Pin		横送り指針軸	1
8		NS-6160520-SP	Nut 1/4-24		横送り支エネジナット	1
9		B2518-372-000	Slide plate connecting link	D.6/83	送り連結リンク	—
9-1		B2518-372-000-A	Slide plate connecting link	A.6/83	送り連結リンク	1
10		SD-0640961-SP	. . . Hinge screw (LARGE) D=6.35 H=9.6	D.6/83	送りレバー結合段ネジ(大)	—
10-1		SD-0640481-SP	Hinge screw D=6.35 H=9.6	A.6/83	送りレバー結合段ネジ(大)	1
11		B2521-372-000	. . . Stud		送りレバー六角軸	1
12		B2519-372-000	. . . Intermediate connecting link		送りリンク	1
13		WP-0501016-SD	. . . Washer 5.0 x 10.5 x 1.0		送りレバー六角軸座金	1
14		NS-6120310-SP	. . . Nut 3/16-28		送りレバー六角軸止ナット	1
15		B2513-372-000	Lengthwise feed adjusting lever base		縦送り量調節レバー台	1
16		SD-0640961-SP	Hinge screw D=6.35 H=9.6		縦送り量調節レバー段ネジ	1
17		B2515-372-000	Lengthwise feed adjusting lever		縦送り量調節レバー	1
18		SS-4090610-SP	Screw 9/64-40 L=6.0		縦送り量調節レバー止ネジ	2
19		B2507-372-000	Feed cam roller		送りカムコロ	2
20		B2511-372-0A0	Lengthwise feed lever asm.		縦送りレバー(組)	1
21		B2512-372-000	. . . Adjusting block		縦送り量調節駒	(1)
22		B2508-372-000	Feed cam roller stud		送りカムコロ軸	2
23		B2509-372-000	Feed stud	D.8/76	送り軸	—
		B2509-372-000-A	Feed stud	A.8/76	送り軸	2
24		B2516-372-000	Lengthwise feed graduated plate	D.1/80	B2563-372-0A0	—
24-1		B2563-372-0A0	Lengthwise feed graduated plate asm.	A.1/80	縦送り目盛(組)	1
24-2		B2563-372-000	Lengthwise feed graduated plate	A.1/80	縦送り目盛	(1)
24-3		B2564-372-000	Lengthwise feed graduated plate base	A.1/80	縦送り目盛取付台	(1)
24-4		B2565-372-000	Stopper	A.1/80	縦送り量調節レバーストッパー	(1)
25		SS-7120640-SP	Screw 3/16-28 L=6.0	D.11/82	SS-4120615-SP	—
		SS-4120615-SP	Screw 3/16-28 L=6	A.11/82	ナベネジ 3/16-28 L=6	2
26		NS-6150540-SP	Nut 15/64-28		前後送り軸止ネジナット	1
27		B2531-372-000	Screw		前後送り軸止ネジ	1
28		SD-0640481-SP	Hinge screw (SMALL) D=6.35 H=4.8		送りレバー結合段ネジ(小)	2
29		B2519-372-000	Feed link		送りリンク	1
30		SS-8152030-SP	Screw 15/64-28 L=20.0		送り軸止ネジ	1
31		B2510-372-000	Crosswise feed lever		横送りレバー	1
32		B2501-372-000	Cam shaft		カム軸	1
33		B2530-372-0A0	Feed cam boss asm.		送りカムボス(組)	2
34		SS-8680810-TP	Screw 9/32-28 L=8.0	A.8/74	送りカムボス止ネジ	(4)
35		B2502-372-000	Cam shaft bushing (RIGHT)		カム軸メタル(右)	1
36		SS-8151150-SP	Screw 15/64-28 L=10.5		メタル止ネジ	2
37	◇01	B2505-372-000	Crosswise feed cam		左右送りカム	1
38	◇02	B2505-373-000	Crosswise feed cam		左右送りカム	1
39		SS-8681412-TP	Screw 9/32-28 L=13.5		送りカム止ネジ	5
40	◇01	B2506-372-000	Lengthwise feed cam		前後送りカム	1
41	◇02	B2506-373-000	Lengthwise feed cam		前後送りカム	1
42		B2503-372-000	Cam shaft bushing (LEFT)		カム軸メタル(左)	1
43		SS-1061010-SP	Screw 3/32-56 L=10.0	D.1/80	SS-7060810-SP	2
		SS-7060810-SP	Screw 3/32-56 L=8	A.1/80	横送り目盛板止ネジ	—
44		B2527-372-000	Crosswise feed graduated plate base	M.12/79	横送り目盛板取付台	2
45		B2528-372-000	Crosswise feed graduated plate		横送り目盛板	1
46		B2523-372-000	. . . Hinge screw		横送り支エネジ	1
47	◇01	B2522-372-000	Feed plate	D.1/83	B2522-373-000-A	—
48	◇02	B2522-373-000	Feed plate	D.8/78	送り台	—
48-1		B2522-373-000-A	Feed plate	A.1/83	送り台	1

Note (注記) ◇01 For MB-372 MB-372用
 ◇02 For MB-373 MB-373用
 ◇04 Special order part for MB-372 MB-372用特別注文部品

6. BUTTON CLAMP LIFTER COMPONENTS

引き上げ関係

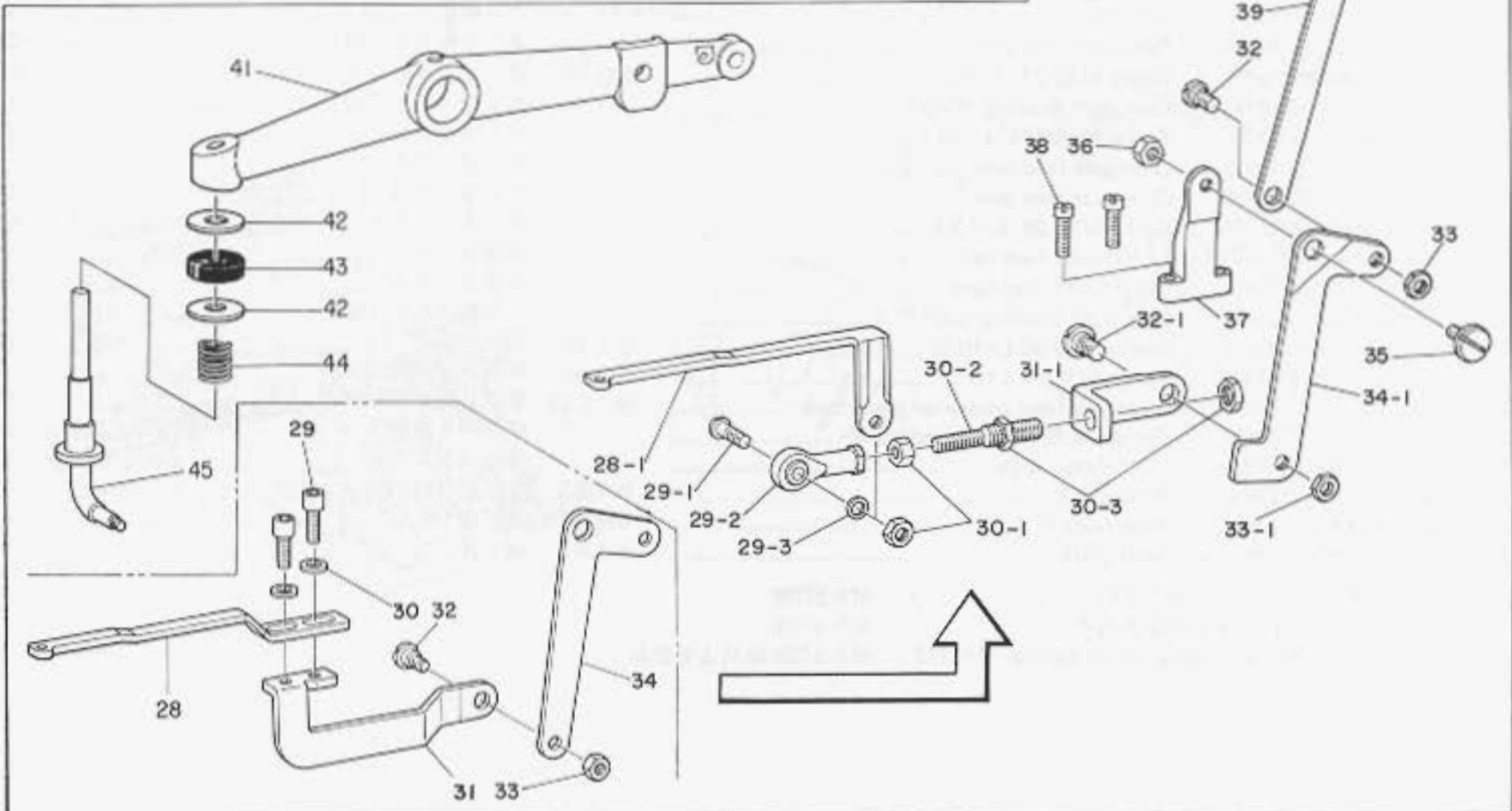
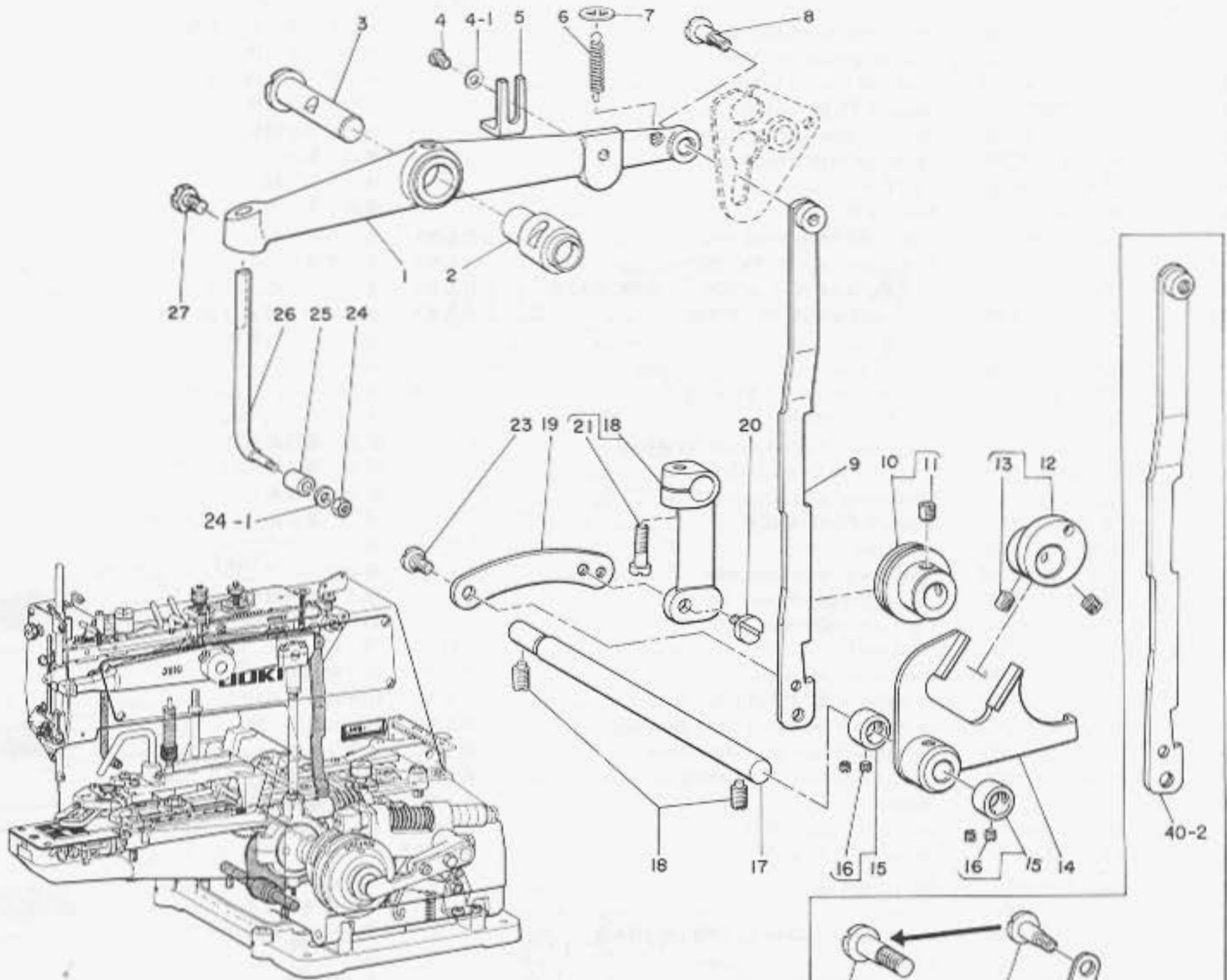

6. BUTTON CLAMP LIFTER COMPONENTS

引キ上げ関係

Ref. No.	Note	Part No.	Description	E.C.	品名	Amt. Req.
	注記	品番		変更年月		数量
1	001	B4412-372-000	Button clamp lifting lever		引キ上げレバー	1
2		B1407-372-000	Bushing		針棒揺動桿支点軸メタル	1
3		B1408-372-000	Button clamp lifting lever shaft		針棒揺動桿支点軸	1
4	001	SS-7150740-SP	Screw 15/64-28 L=7.0		引キ上げレバーストッパー板止ネジ	1
4-1		WP-0851846-SC	Washer	A.1/83	ストッパー座金(E)	1
5	001	B4415-372-000	Lifting lever stopper plate		引キ上げレバーストッパー板	1
6		B4419-372-000	Spring		引キ上げレバー引張バネ	1
7		B4418-372-000	Washer		引キ上げレバー引張バネ座金	1
8	001	SD-0641001-SP	Hinge screw D=6.35 H=10.0		引キ上げレバー段ネジ	1
9	001	B4411-372-000-A	Button clamp lifting link		引キ上げ板	1
10		B4410-372-0A0	Slide guide asm.		引キ上げ板スライド案内(組)	1
11		SS-8660612-TP	Screw 1/4-40 L=6.0	M.1/79	引キ上げ板スライド案内止ネジ	(1)
12		B4405-372-0A0	Eccentric cam asm.		引キ上げ偏心カム(組)	1
13		SS-8660612-TP	Screw 1/4-40 L=6.0		引キ上げ偏心カム止ネジ	(2)
14		B4401-372-0A0	Button clamp forked rod asm.		引キ上げニ又ロッド(組)	1
15		CS-0950810-SH	Thrust collar asm.		引キ上げニ又ロッドスラストカラー(組)	2
16		SS-8110410-TP	Screw 11/64-40 L=3.5		引キ上げニ又ロッドスラストカラー止ネジ	(4)
17		B4404-372-000	Shaft		引キ上げニ又ロッド軸	1
18		SS-8151150-SP	Screw 15/64-28 L=10.5		引キ上げニ又ロッド軸止ネジ	2
19		B4408-372-000	Lifting link connecting link		引キ上げ板リンク	1
20		B4406-372-0A0	Button clamp lifting link lever asm.	D.9/79	引キ上げ板案内ロッド(組)	-
		B4406-372-0A0-A	Button clamp lifting link lever asm.	A.9/79	引キ上げ板案内ロッド(組)	1
21		SS-6121610-TP	Screw 3/16-28 L=15.5		引キ上げ板案内ロッド止ネジ	(1)
22		SD-0640471-SP	Hinge screw D=6.35 H=4.7		引キ上げ板案内ロッド段ネジ	1
23		SD-0640211-SP	Hinge screw D=6.35 H=2.1		引キ上げ板リンク段ネジ	1
24		NS-6090530-SP	Nut 9/64-40	D.11/79	NS-6090310-SP	-
		NS-6090310-SP	Nut 9/64-40	A.11/79	L型引キ上げ棒ナット	1
24-1		WP-0371026-SD	Washer 3.7 x 7 x 1	A.11/79	L型引キ上げ棒ナット座金	1
25		B4417-372-000	Button clamp lifting rod roller		L型引キ上げ棒コロ	1
26	001	B4416-372-000	Button clamp lifting rod		L型引キ上げ棒	1
27		SS-9151120-SP	Screw 15/64-28 L=11.0	D.11/79	SS-9151120-CP	-
		SS-9151120-CP	Screw 15/64-28 L=11.0	A.11/79	L型引キ上げ棒止ネジ	1
28	002	B2404-373-000	Thread trimming connecting link (SMALL)	D.8/78	糸切り連結板(小)	-
28-1	002	B2404-373-000-A	Thread trimming connecting link (FRONT)	D.7/81	B2404-373-R00	-
	002	B2404-373-R00	Thread trimming connecting link (FRONT)	A.7/81	糸切り連結板(前)	1
29	002	SS-6121212-TP	Screw 3/16-28 L=12.0	D.8/78	糸切り連結板(小)止ネジ	-
29-1	002	B2413-373-000	Joint stud	A.8/78	糸切り連結ジョイント軸	1
29-2	002*	B1632-180-000	Joint	A.8/78	糸切り連結ジョイント	1
29-3	002	WP-0510516-SD	Washer 5.1 x 7.5 x 0.5	A.8/78	糸切り連結ジョイント軸座金	1
30	002	WP-0501016-SC	Washer 5.0 x 10.5 x 1.0	D.8/78	糸切り連結板(小)止ネジ座金	-
30-1	002	NM-6050001-SP	Nut M5	A.8/78	糸切り連結ジョイント軸止ナット	2
30-2	002	B2412-373-000	Connecting screw	A.8/78	糸切り連結ネジ	1
30-3	002	NS-6680330-SP	Nut 9/32-28	D.7/79	NS-6680320-SP	-
	002	NS-6680320-SP	Nut 9/32-28	A.7/79	糸切り連結ネジナット	2
31	002	B2403-373-000	Thread trimming connecting link (LARGE)	D.8/78	糸切り連結板(大)	-
31-1	002	B2403-373-000-A	Thread trimming connecting link (REAR)	A.8/78	糸切り連結板(後)	1
32	002	SD-0640323-TP	Hinge screw D=6.35 H=3.2	M.8/78	糸切り連結板(大)段ネジ	1
32-1	002	SD-0790402-TP	Hinge screw D=7.94 H=4	A.8/78	糸切り連結板(後)段ネジ	1
33	002	NS-6620310-SP	Nut 3/16-32	M.8/78	糸切り連結板(大)段ネジナット	1
33-1	002	NS-6150320-SP	Nut 15/64-28	D.8/79	NS-6150310-SP	-
	002	NS-6150310-SP	Nut 15/64-28	A.8/79	糸切り連結板(後)段ネジナット	1
34	002	B2402-373-000	Thread trimming lever	D.8/78	糸切りレバー	-
34-1	002	B2402-373-000-A	Thread trimming lever	A.8/78	糸切りレバー	1
35	002	SD-0790311-SP	Hinge screw D=7.94 H=3.1	D.6/75	SD-0790311-TP	-
	002	SD-0790311-TP	Hinge screw D=7.94 H=3.1	A.6/75	糸切りレバー段ネジ	1
36	002	NS-6110530-SP	Nut 11/64-40		糸切りレバー段ネジナット	1
37	002	B2405-373-000	Thread trimming lever base		糸切りレバー台	1
38	002	SS-7111410-TP	Screw 11/64-40 L=14.0		糸切りレバー台止ネジ	2
39	002	B2401-373-000	Thread trimming link		糸切りリンク	1
40	002	SD-0641321-TP	Hinge screw D=6.35 H=13.20	D.12/80	糸切りリンク段ネジ	1
40-1	002	SD-0641322-TP	Hinge screw D=6.35 H=13.2	A.12/80	糸切りリンク段ネジ	1
40-2	002	B4411-373-000	Button clamp lifting link	C.8/84	B4411-372-000	1
41	002	B4412-373-000	Button clamp lifting lever	A.12/77	引キ上げレバー	1
42	002	WP-0751576-SD	Washer 7.5 x 19.0 x 1.5	A.12/77	遮断クッションバネ座金	2
43	002	B4420-373-000	Cushion	A.12/77	遮断クッション	1
44	002	D9219-555-B00	Spring	A.12/77	遮断クッションバネ	1
45	002	B4416-373-AA0	Button clamp lifting rod asm.	A.12/77	L型引キ上げ棒(組)	1

Note (注記) 001 For MB-372 MB-372用
002 For MB-373 MB-373用

7. NEEDLE DRIVING PULLEY SHAFT COMPONENTS

駆動軸関係

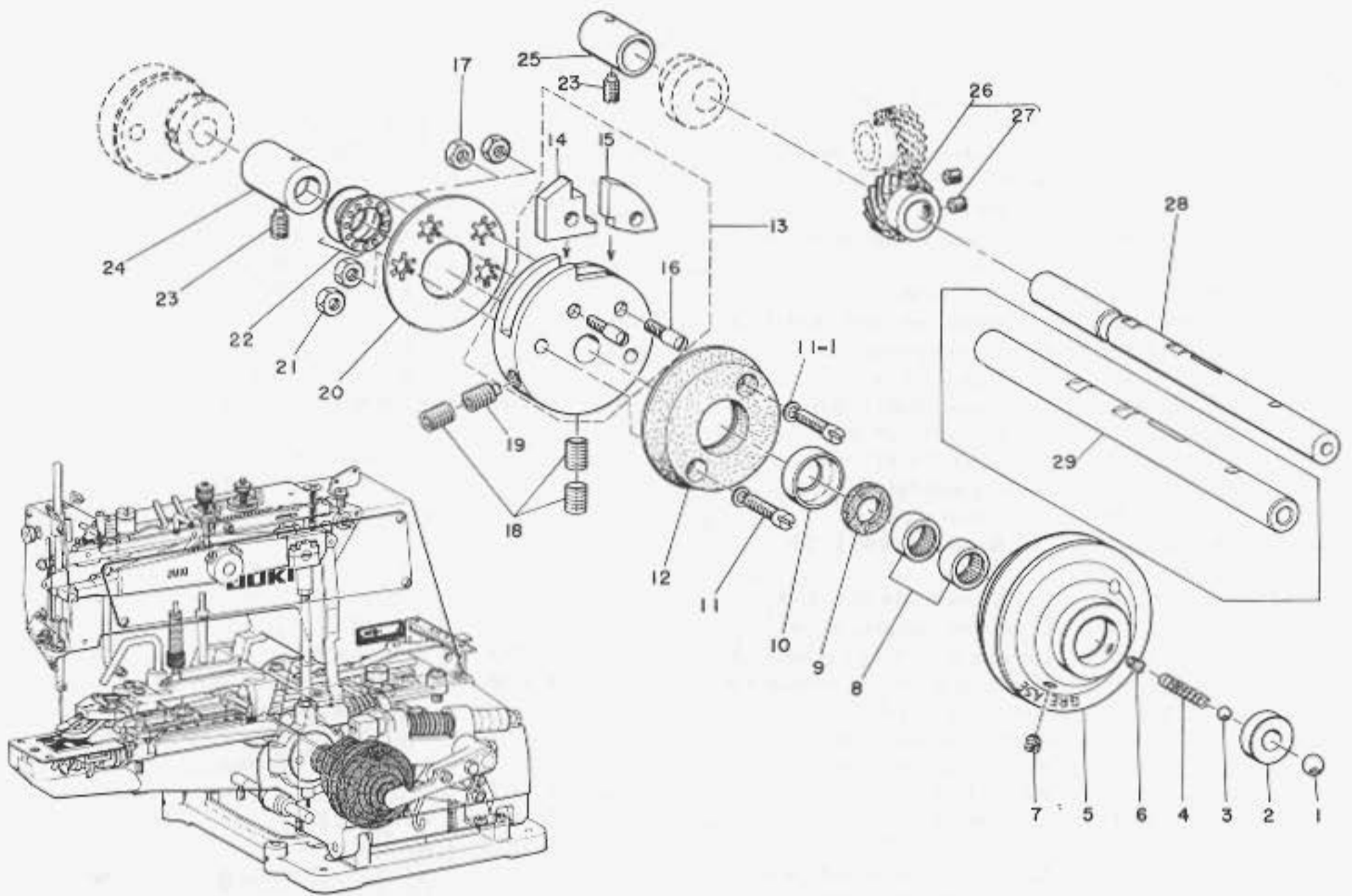

Ref. No.	Note	Part No.	Description	E.C.	品名	Amt. Req.
	注記	品番		変更年月		数量
1		B1203-372-000	Driving ball		起動ボール	1
2		B1204-372-000	Pulley insert		起動ボール受台	1
3		B1246-372-000	Spring ball		主軸用バネボール	1
4		B1205-372-000	Spring		主軸用バネ	1
5		B1202-372-000	Needle driving pulley		駆動プーリー	1
6		SS-8110750-SP	Screw 11/64-40 L=6.5	M.12/78	起動ボール受台止ネジ	1
7		SS-8150410-SP	Screw 15/64-28 L=4.0		油止ネジ	1
8		B1243-372-000	Needle bearing		ニードルベアリング	2
9		B1206-372-000	Main shaft oil shield felt		主軸油止フェルト	1
10		B1207-372-000	Case		主軸油止フェルトケース	1
11		SS-6152440-SP	Screw 15/64-28 L=23.5		駆動クッション止ネジ	2
11-1		WP-0621026-SP	Washer	A.4/84	駆動クッション止ネジ座金	2
12		B1208-372-000	Needle driving pulley clutch disc		駆動クッション	1
13		B1210-372-0A0	Stop motion disc asm.		遮断カム(組)	1
14		B1211-372-000	Stop motion disc pawl (A)		遮断用爪(A)	(1)
15		B1212-372-000	Stop motion disc pawl (B)		遮断用爪(B)	(1)
16		B1213-372-000	Screw		遮断用爪止ネジ	(2)
17		NS-6150430-SP	Nut 15/64-28		遮断用爪(A)(B)止ナット	2
18		SS-8701042-TP	Screw (B) 5/16-24 L=10.0		遮断カム止ネジ(B)	3
19		SS-8701782-TP	Screw (A) 5/16-24 L=17.0		遮断カム止ネジ(A)	1
20		B1214-372-000	Washer		遮断カム座金	1
21		NS-6150430-SP	Nut 15/64-28		駆動クッション止ナット	2
22		B1215-372-B00	Thrust bearing		駆動軸用スラストベアリング	1
23		SS-8151150-SP	Screw 15/64-28 L=10.5		駆動軸メタル止ネジ	2
24		B1216-372-000	Pulley shaft bushing (RIGHT)		駆動軸メタル(右)	1
25		B1218-372-000	Pulley shaft bushing (LEFT)		駆動軸メタル(左)	1
26		B1217-372-0A0	Driving gear (A) asm.		ネジ歯車(A)(組)	1
27		SS-8660612-TP	Screw 1/4-40 L=6.0		ネジ歯車(A)止ネジ	(2)
28	001	B1201-372-000	Needle driving pulley shaft		駆動軸	1
29	002	B1201-373-000	Needle driving pulley shaft		駆動軸	1

Note (注記) 001 For MB-372 MB-372用
 002 For MB-373 MB-373用

8. NEEDLE BAR DRIVING MECHANISM COMPONENTS

針棒関係

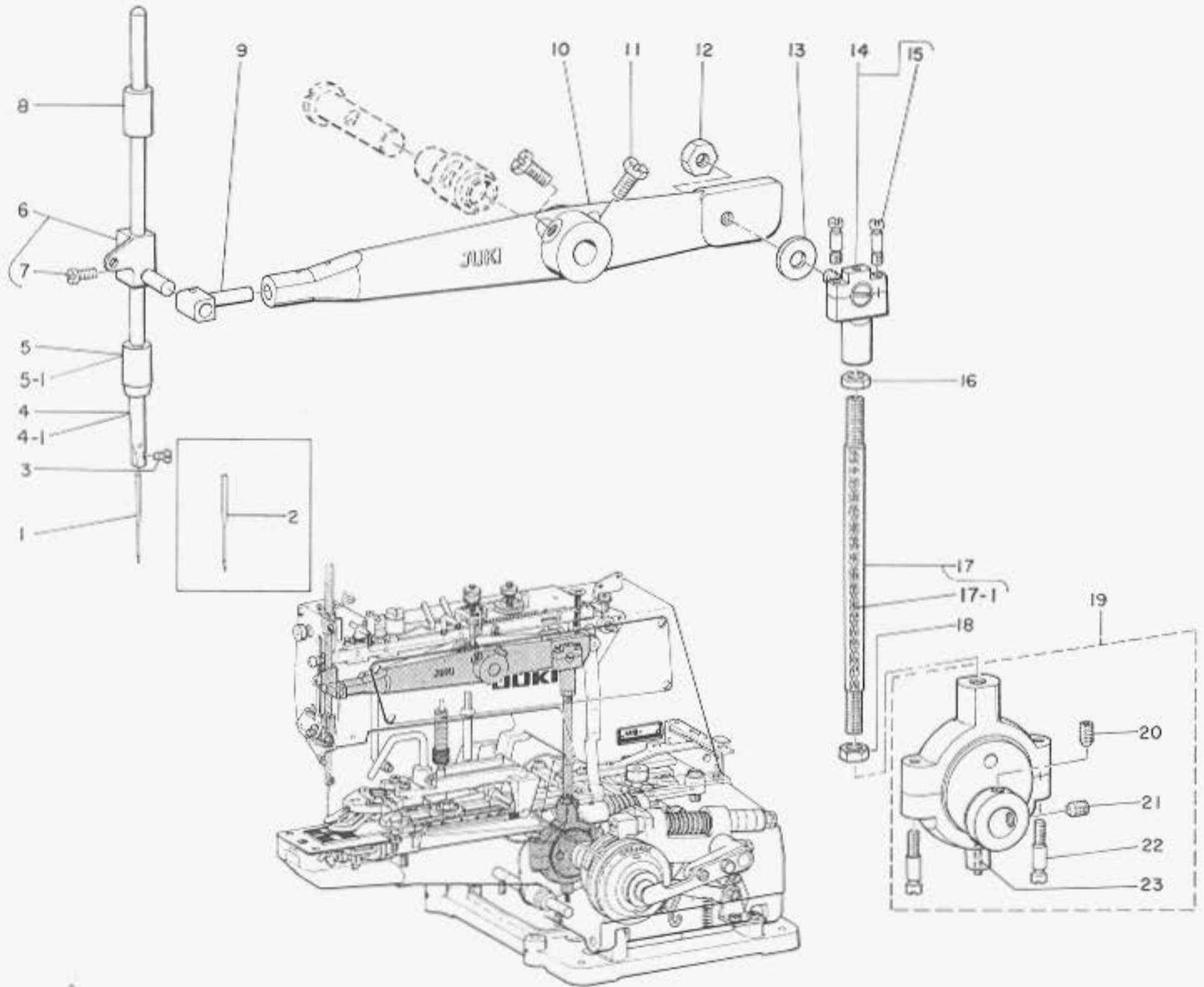

Ref. No.	Note	Part No.	Description	E.C.	品名	Amt. Req.
	注記	品番		変更年月		数量
1	001	MTQ-700B1600	Needle (TQx7) #16		針(TQ×7)#16	1
2	002	MTQ-700B2000	Needle (TQx7) #20		針(TQ×7)#20	1
3		SS-7080510-SP	Screw 1/8-44 L=4.5	D.9/80	SS-7080510-TP	—
		SS-7080510-TP	Screw 1/8-44 L=4.5	A.9/80	針止ネジ	—
4		B1401-372-000	Needle bar	D.7/83	針棒	—
4-1		B1401-372-000-A	Needle bar	A.7/83	針棒	1
5		B1403-372-000	... Bushing, lower	D.7/83	針棒下メタル	1
5-1		B1403-372-000-A	... Bushing, lower	A.7/83	針棒下メタル	1
6		B3102-372-0A0	... Thread take-up asm.		針棒天秤(組)	1
7		SS-7090910-TP	... Screw 9/64-40 L=8.5		針棒天秤止ネジ	(1)
8		B1402-372-000	... Bushing, upper		針棒上メタル	1
9	005	B1406-372-000	... Clamp slide block		針棒抱キスライド駒	1
10		B1409-372-000	Needle bar lever		針棒揺動桿	1
11		SS-9151630-CP	Screw 15/64-28 L=15.5		針棒揺動桿止ネジ	2
12		NS-6150440-SP	Nut 15/64-28		クランクロッド(小)止ナット	1
13	005	B1411-372-A00	Crank pin washer		クランクピン座金	1
14		B1412-372-0A0	Crank rod (SMALL) asm.		クランクロッド(小)(組)	1
15		B1413-372-000	... Clamp screw		クランクロッド(小)締ネジ	(2)
16		NS-6680410-SP	Nut 9/32-28		クランク棒止ナット	1
17		B1414-372-0A0	Needle bar lever connecting rod asm.	C.7/76	B1414-372-000	1
17-1		CO-2000000-00	... Oil wick	A.7/76	クランク棒油心	(0.3)
18		NS-6680480-SP	Nut 9/32-28		クランク棒下ナット	1
19		B1416-372-0A0	Ball joint, eccentric asm.		偏心球形カム(組)	1
20		SS-8660612-TP	Screw (A) 1/4-40 L=8.5		偏心球形カム止ネジ(A)	(1)
21		SS-8660942-TP	Screw (B) 1/4-40 L=6.0		偏心球形カム止ネジ(B)	(1)
22		B1418-372-000	Crank rod (LARGE) clamp screw		クランクロッド(大)締ネジ	(2)
23		B1419-372-000	... Oil wick	C.7/76	CO-2000000-00	(0.1)

Note (注記) 001 For MB-372 MB-372用

002 For MB-373 MB-373用

005 Selective part 選択部品

9. STOP MOTION MECHANISM COMPONENTS

遮断装置関係

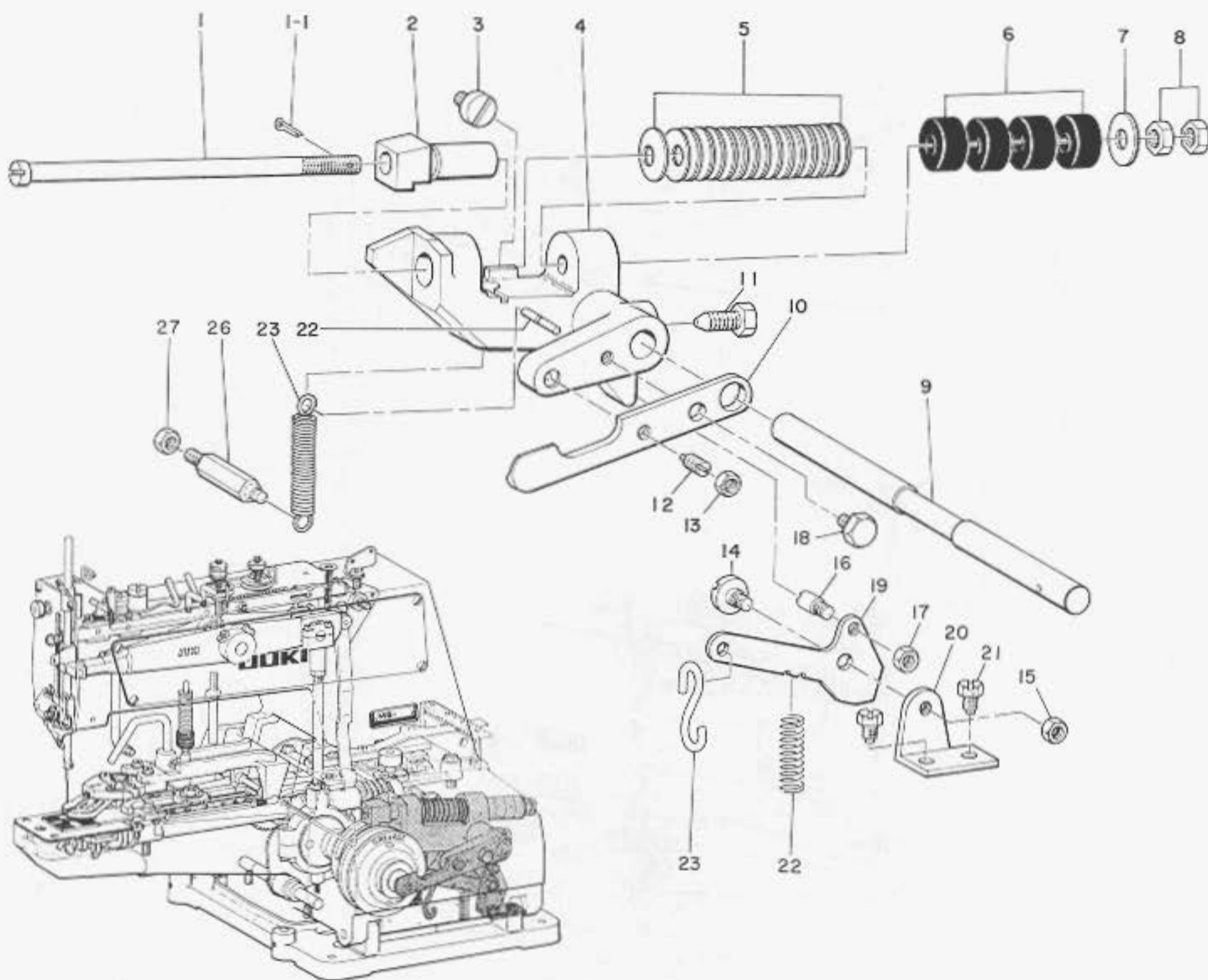

Ref. No.	Note	Part No.	Description	E.C.	品名	Amt. Req.
	注記	品番		変更年月		数量
1		B2605-372-000	Stop motion plunger rod		遮断用圧縮軸	1
1-1		PD-0201000-0B	... Cotter pin	D.1/81	PD-0201000-0D	—
		PD-0201000-0D	... Cotter pin	A.1/81	遮断用圧縮軸安全ピン	1
2		B2604-372-000	... Plunger		遮断用フック	1
3		SS-6151040-SP	... Screw 15/64-28 L=10.0		遮断装置ストッパーネジ	1
4		B2602-372-000	... Frame		遮断フレーム	1
5		B2606-372-000	... Disc spring		遮断用圧縮バネ	30
6		B2607-372-000	... Rubber cushion	D.8/79	B2608-280-000	—
		B2608-280-000	... Rubber cushion	A.8/79	遮断用ゴムクッション	4
7		WP-0751576-SD	... Washer 7.5 x 19.0 x 1.5	D.9/78	B8220-804-000	—
		B8220-804-000	... Washer	A.9/78	遮断用ゴムクッション座金	1
8		NS-6680410-SP	... Nut 9/32-28		遮断バネ調節ナット	2
9		B2601-372-000	... Lever shaft		遮断軸	1
10		B2611-372-000	... Pressure applying lever		駆動プーリー押し付板	1
11		B2603-372-000	... Set screw		遮断装置取付ネジ	1
12		SS-8151570-SP	Screw 15/64-28 L=15.0		駆動プーリー押し付調節ネジ	1
13		NS-6150310-SP	Nut 15/64-28		駆動プーリー押し付調節ナット	1
14		SD-0680271-SP	Hinge screw D=6.80 H=2.7		起動リンク止ネジ	1
15		NS-6150310-SP	Nut 15/64-28		起動リンク止ネジナット	1
16		B2615-372-000	Stop motion trip lever pin		起動リンクピン	1
17		NS-6150310-SP	Nut 15/64-28		起動リンク止ピンナット	1
18		SS-9151160-SP	Screw 15/64-28 L=10.5		駆動プーリー押し付板止ネジ	1
19		B2614-372-000	Stop motion trip lever		起動リンク	1
20		B2612-372-000	... Bracket		起動リンク取付台	1
21		SS-9150860-SP	... Screw 15/64-28 L=8.0		起動リンク取付台止ネジ	2
22		B2616-372-000	... Spring		起動リンク返しバネ	1
23		B8133-019-000	"S" chain hook		S型金具	1
24		B2608-372-000	Spring pin		遮断装置引張りバネ止ピン	1
25		B2609-372-000	Spring		遮断フレーム引張りバネ	1
26		B2610-372-000	... Screw		遮断装置引張りバネ止ネジ	1
27		NS-6150310-SP	... Nut 15/64-28		遮断装置引張りバネ止ナット	1

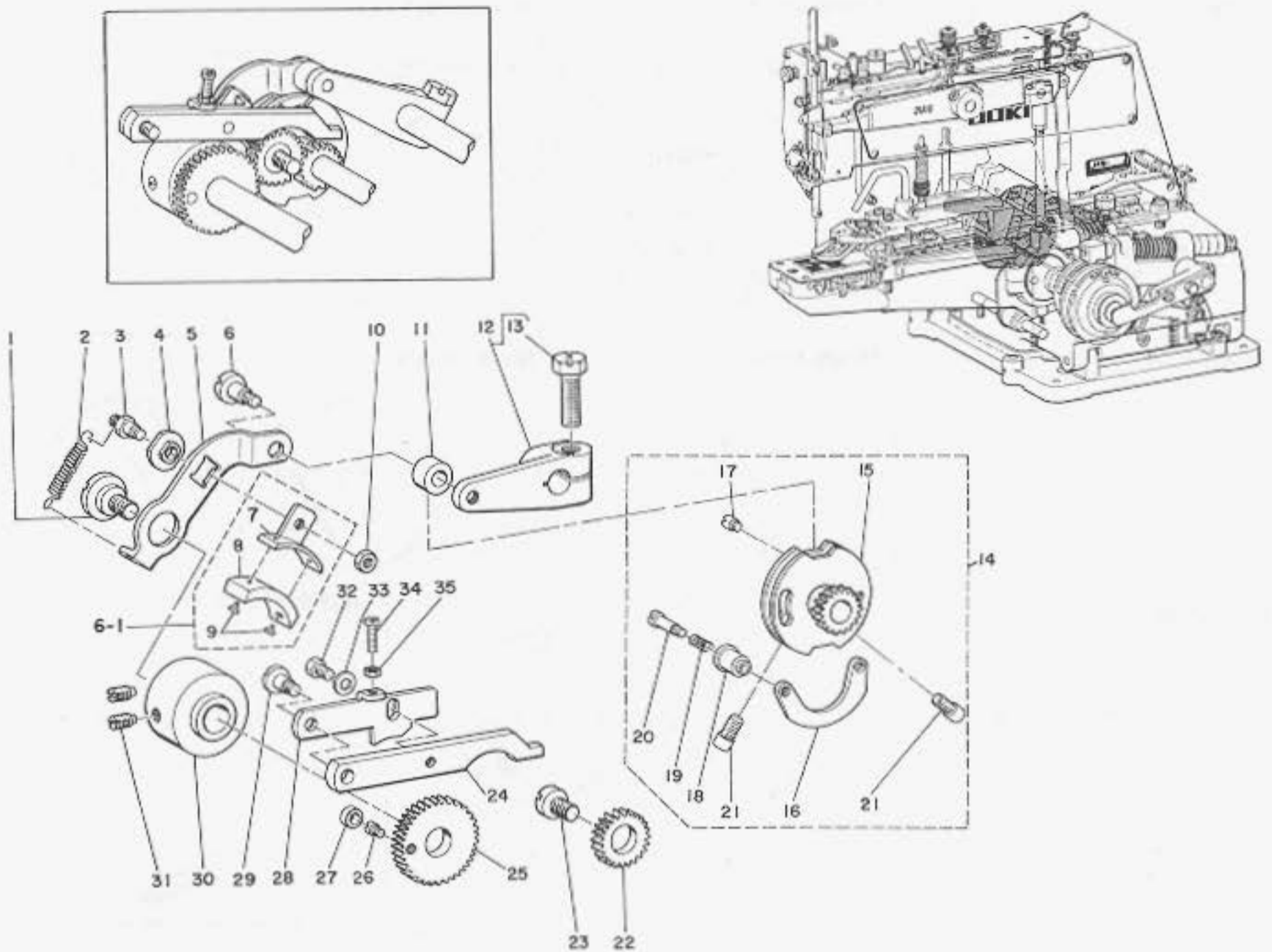

Ref. No.	Note	Part No.	Description	E.C.	品名	Amt. Req.
	注記	品番		変更年月		数量
1		SD-1127321-SP	Hinge screw D=12.70 H=3.2		予備停止レバー止ネジ	1
2		B2643-372-000	Friction plate spring		摩擦板引張りバネ	1
3		B2638-372-000	Rotating stud		摩擦板回転軸	1
4		B2637-372-000	Friction wheel slide block		摩擦車スライド駒	1
5		B2636-372-000	Speed slowing lever		予備停止レバー	1
6		SD-0791331-SP	Hinge screw D=7.94 H=13.3		針数調節コロ軸	1
6-1		B2639-372-0A0	Friction plate holder asm.	A.9/76	摩擦板取付台(組)	1
7		B2639-372-000	Friction plate holder		摩擦板取付台	(1)
8		B2640-372-000	Speed slowing friction plate		予備停止摩擦板	(1)
9		B2641-372-000	Friction plate caulking pin		摩擦板カシメピン	(2)
10		NS-6110310-SP	Nut 11/64-40		摩擦板取付台ナット	1
11		B2619-372-000	Stitch adjusting cam roller		針数調節コロ	1
12		B2618-372-0A0	Lever asm.		針数調節コロ腕(組)	1
13		SS-9202443-CP	Screw 5/16-18 L=22.0		針数調節コロ腕止ネジ	(1)
14		B2621-372-0B0	Stitch adjusting cam asm.		針数調節カム(組)	1
15		B2621-372-0A0	Stitch adjusting cam asm.		針数調節カム(組)	(1)
16		B2623-372-000	Stitch adjusting plate		針数調節板	(1)
17		B2624-372-000	Screw		針数調節板止ネジ	(1)
18		B2625-372-000	Cam knob		針数調節つまみ	(1)
19		B2626-372-000	Spring		針数調節つまみバネ	(1)
20		SD-0481451-SP	Hinge screw D=4.80 H=14.5		針数調節つまみバネ軸	(1)
21		SS-6151142-TP	Screw 15/64-28 L=10.5		針数調節カム止ネジ	(2)
22		B2629-372-000	Stitch adjusting gear (INTERMEDIATE)		針数調節歯車(中)	1
23		B2628-372-000	Intermediate gear stud		中間歯車軸	1
24		B2633-372-000	Stitch selecting lever (LARGE)		針数調節レバー(大)	1
25		B2630-372-000	Stitch adjusting gear (LARGE)		針数調節歯車(大)	1
26		B2631-372-000	Screw		針数調節歯車(大)ネジ	1
27		B2632-372-000	Roller		針数調節歯車(大)コロ	1
28		B2634-372-000	Stitch selecting lever (SMALL)		針数調節レバー(小)	1
29		SD-0640961-SP	Hinge screw D=6.35 H=9.6		針数調節レバー止ネジ	1
30		B2635-372-000	Speed slowing friction wheel		予備停止摩擦車	1
31		SS-8151150-TP	Screw 15/64-28 L=10.5		予備停止摩擦車止ネジ	2
32		SS-9111010-SP	Screw 11/64-40 L=9.5		針数調節レバー結合ボルト	1
33		WP-0501016-SD	Washer 5.0 x 10.5 x 1.0		針数調節レバー座金	1
34		SS-6081210-SP	Screw 1/8-44 L=12.0		針数調節レバーストッパーネジ	1
35		NS-6080210-SP	Nut 1/8-44		針数調節レバーストッパーナット	1

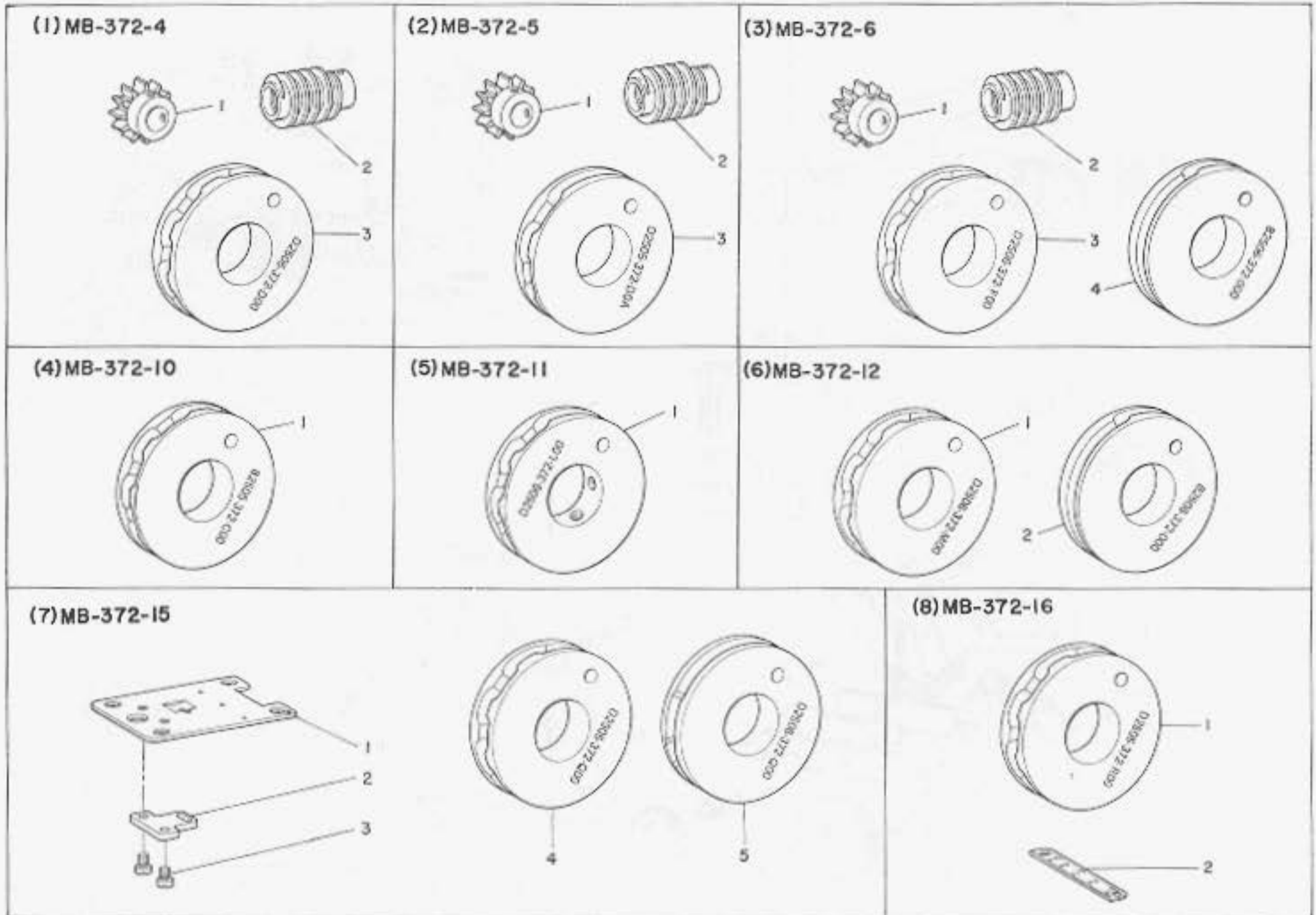

Ref. No.	Note	Part No.	Description	E.C.	品名	Amt. Req.
	注記	品番		変更年月		数量
(1) MB-372-4						
1		D1220-372-D00	Worm gear, 6,12,24 stitches		6、12、24針用ウォーム歯車	1
2		D1221-372-D00	... Worm		6、12、24針用ウォーム	1
3		D2505-372-D00	... Crosswise feed cam, □-shape		6、12、24針ニノ字縫用左右送りカム	1
(2) MB-372-5						
1		D1220-372-D00	Worm gear, 6,12,24 stitches		6、12、24針用ウォーム歯車	1
2		D1221-372-D00	... Worm		6、12、24針用ウォーム	1
3		D2505-372-D0A	... Crosswise feed cam, Z-shape		6、12、24針Z縫用左右送りカム	1
(3) MB-372-6						
1		D1220-372-D00	Worm gear, 6,12,24 stitches		6、12、24針用ウォーム歯車	1
2		D1221-372-D00	... Worm		6、12、24針用ウォーム	1
3		D2505-372-D00	... Crosswise feed cam, □-shape	D.8/75	D2506-372-F00	-
		D2506-372-F00	... Lengthwise feed cam, □-shape	A.8/75	6、12、24針門縫用前後送りカム	1
4	◆01	B2506-372-000	Lengthwise feed cam		前後送りカム	1
(4) MB-372-10						
1		B2505-372-C00	Crosswise feed cam, Z-shape, 8,16,32		8、16、32針Z縫用左右送りカム	1
(5) MB-372-11						
1		D2506-372-L00	Lengthwise feed cam, X-shape, 8,16,32		8、16、32針X字縫用前後送りカム	1
(6) MB-372-12						
1		D2506-372-M00	Lengthwise feed cam, □-shape, 8,16,32		8、16、32針門縫用前後送りカム	1
2	◆01	B2506-372-000	Lengthwise feed cam		前後送りカム	1
(7) MB-372-15						
1		D1241-372-Q00	Throat plate, subclass No.15		SUB15用針板	1
2		D1250-372-Q00	... Needle hole guide		SUB15用針穴ガイド	1
3		SS-7110510-TP	... Screw 11/64-40 L=5.0		針穴ガイド止ネジ	2
4		D2505-372-Q00	... Crosswise feed cam		SUB15用左右送りカム	1
5		D2506-372-Q00	... Lengthwise feed cam		SUB15用前後送りカム	1
* This machine uses, in combination, Z016 (Attachment for second process of wrapped-around buttons).						
* このマシンはZ016(根巻第二工程用アタッチメント)を共用します。						
(8) MB-372-16						
1		D2505-372-R00	Crosswise feed cam, narrow width.....		小振用左右送りカム	1
2		D2528-372-R00	... Crosswise feed graduated plate		小振用横送り目盛板	1

* This machine uses, in combination, Z010-B (Attachment for Louis type shank buttons).
 * このマシンはZ010-B(ルイスタ입パールボタン用アタッチメント)を共用します。

Note (注記) ◆01 Lengthwise feed cam of MB-372 is used as crosswise feed cam.

MB-372の前後送りカムを左右送りカムとして使用します。

☆ All parts not mentioned above are same as those of Model MB-372.

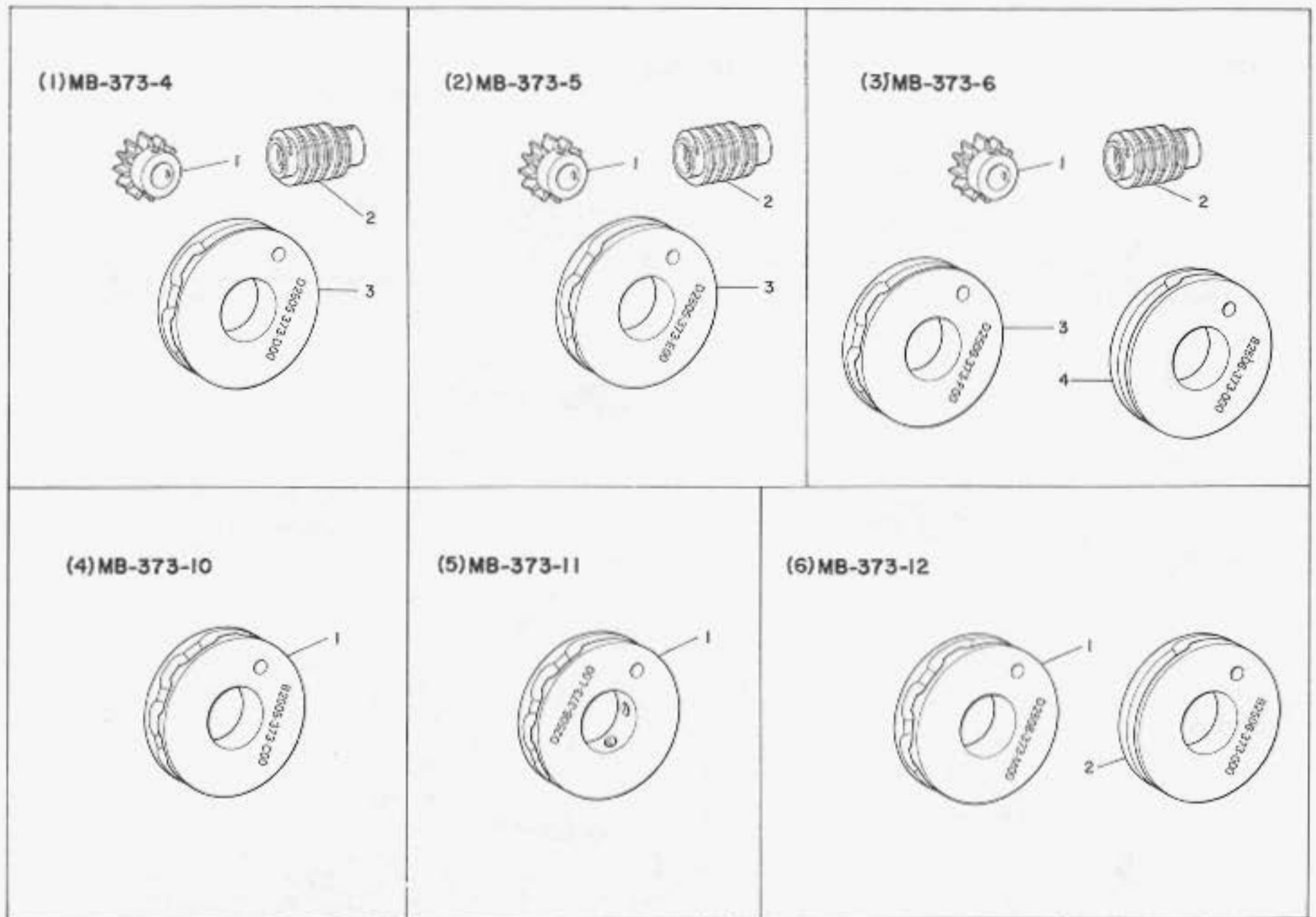

Ref. No.	Note	Part No.	Description	E.C.	Amt. Req.
	注記	品番		変更年月	数量
(1) MB-373-4					
1		D1220-372-D00	Worm gear, 6,12,24 stitches		1
2		D1221-372-D00	... Worm		1
3		D2505-373-D00	... Crosswise feed cam, □-shape		1
(2) MB-373-5					
1		D1220-372-D00	Worm gear, 6,12,24 stitches		1
2		D1221-372-D00	... Worm		1
3		D2505-373-E00	... Crosswise feed cam, Z-shape		1
(3) MB-373-6					
1		D1220-372-D00	Worm gear, 6,12,24 stitches		1
2		D1221-372-D00	... Worm		1
3		D2505-373-D00	... Crosswise feed cam, □-shape	D.8/75	—
		D2506-373-F00	... Lengthwise feed cam, 冂-shape	A.8/75	1
4	◆02	B2506-373-000	Lengthwise feed cam		1
(4) MB-373-10					
1		B2505-373-C00	Crosswise feed cam, Z-shape, 8,16,32		1
(5) MB-373-11					
1		D2506-373-L00	Lengthwise feed cam, X-shape, 8,16,32		1
(6) MB-373-12					
1		D2506-373-M00	Lengthwise feed cam, 冂-shape, 8,16,32		1
2	◆02	B2506-373-000	Lengthwise feed cam		1

Note (注記) ◆02 Lengthwise feed cam of MB-373 is used as crosswise feed cam.
 MB-373の前後送りカムを左右送りカムとして使用します。
 ☆ All parts not mentioned above are same as those of Model MB-373.
 ☆ 上記以外の部品はMB-373と共通です。

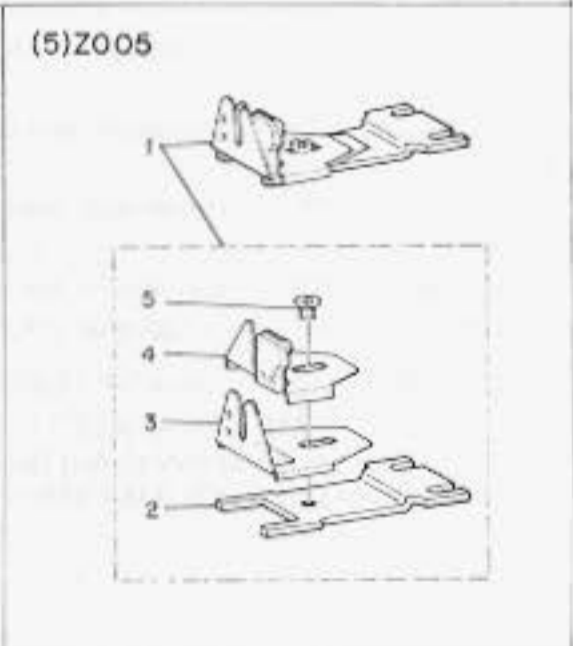
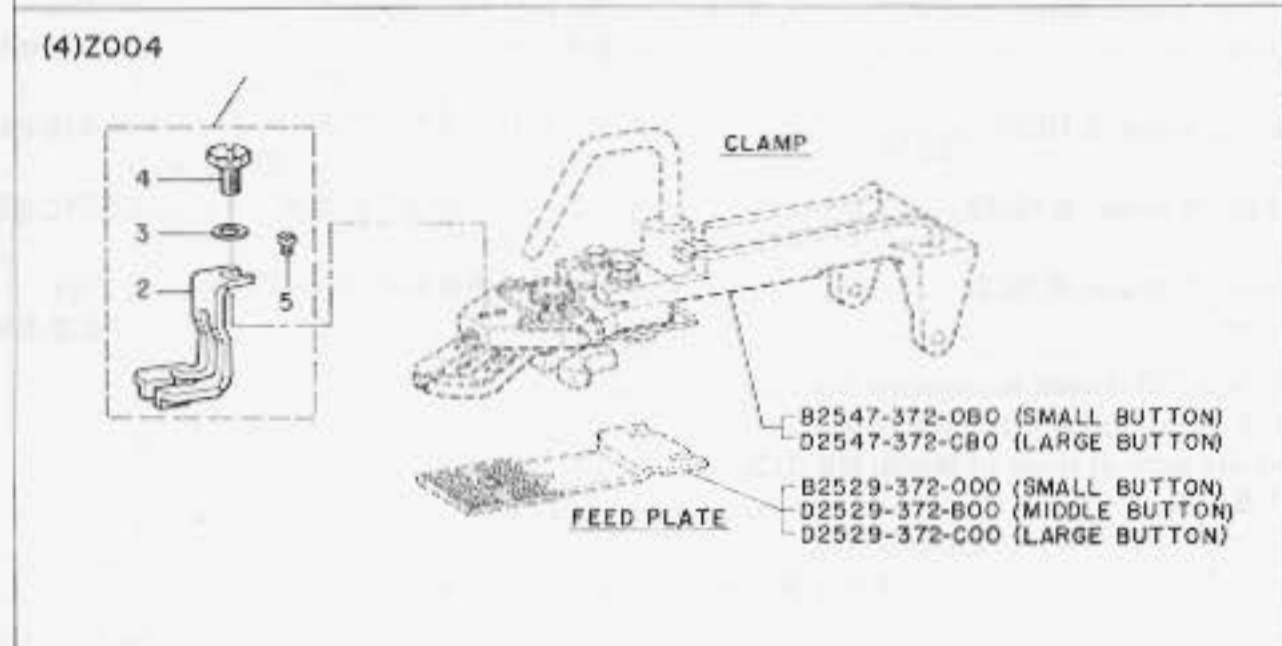
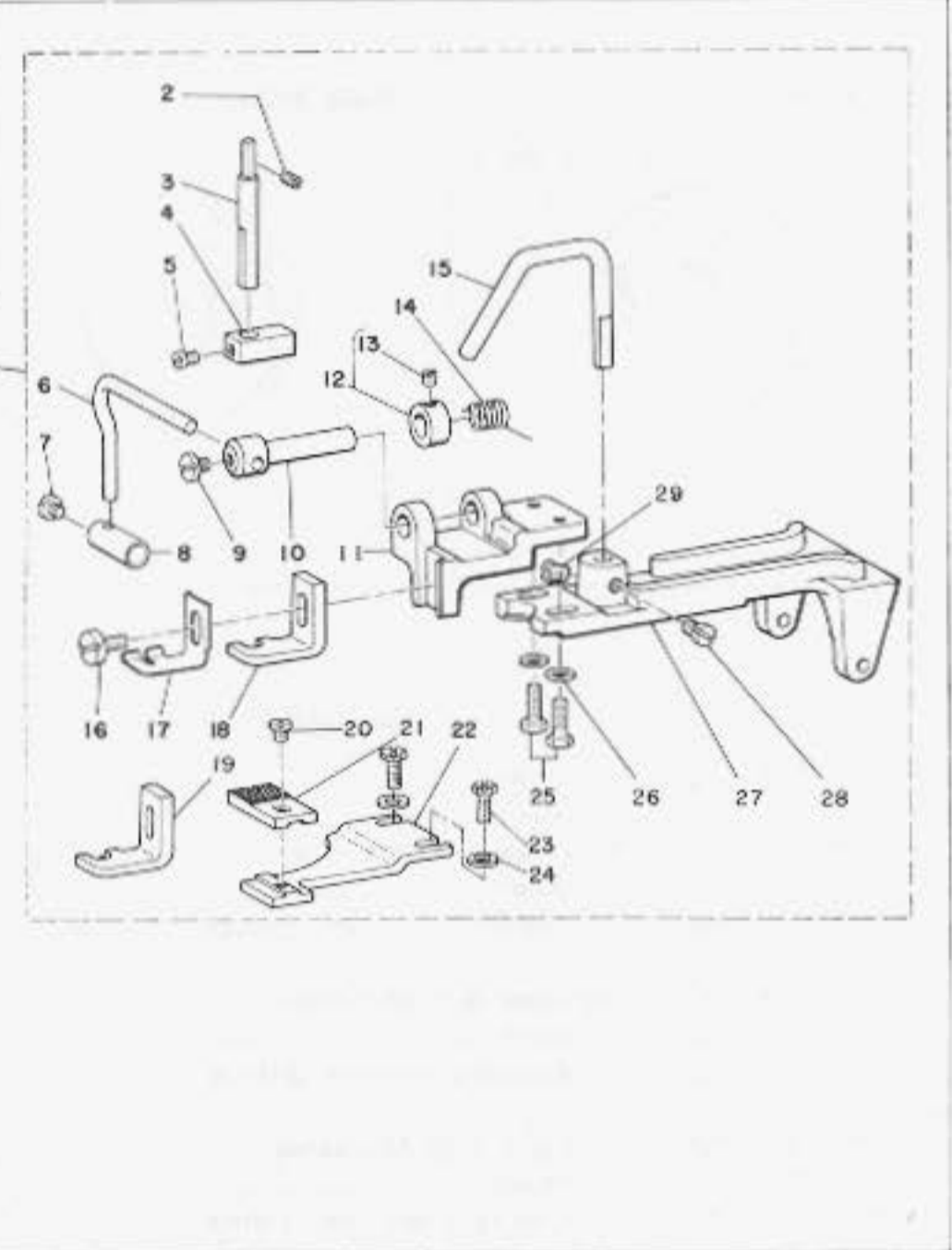
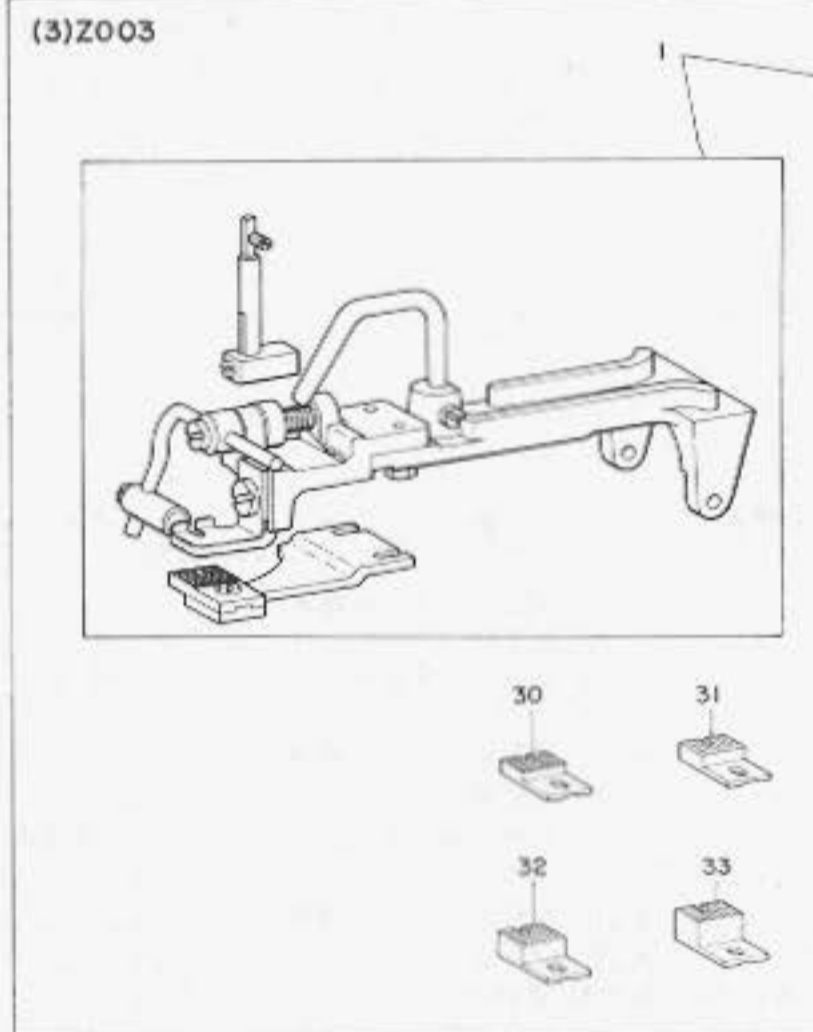
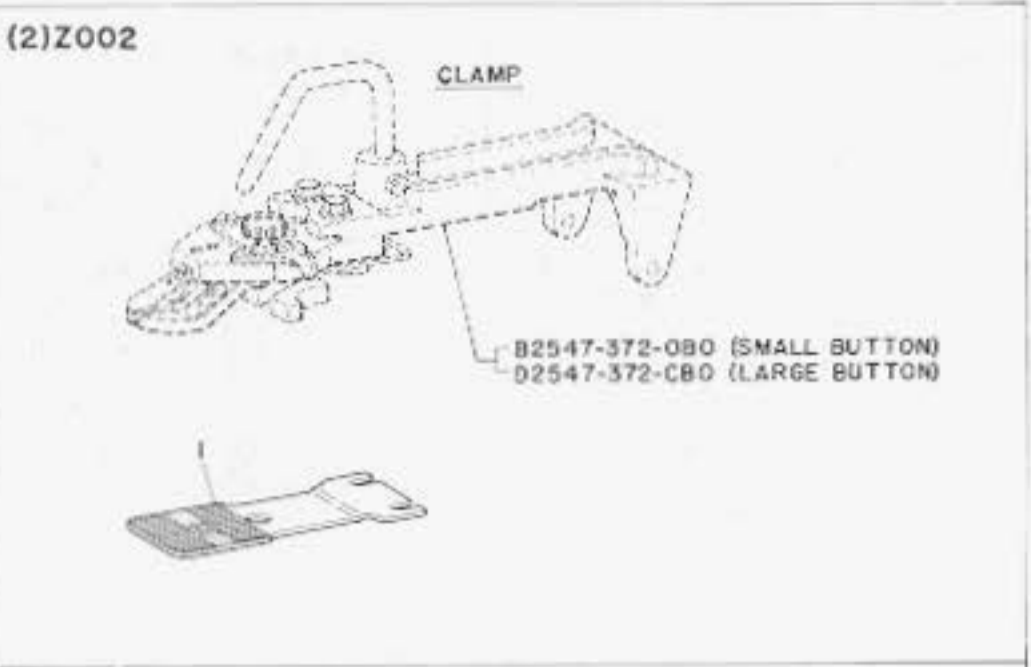
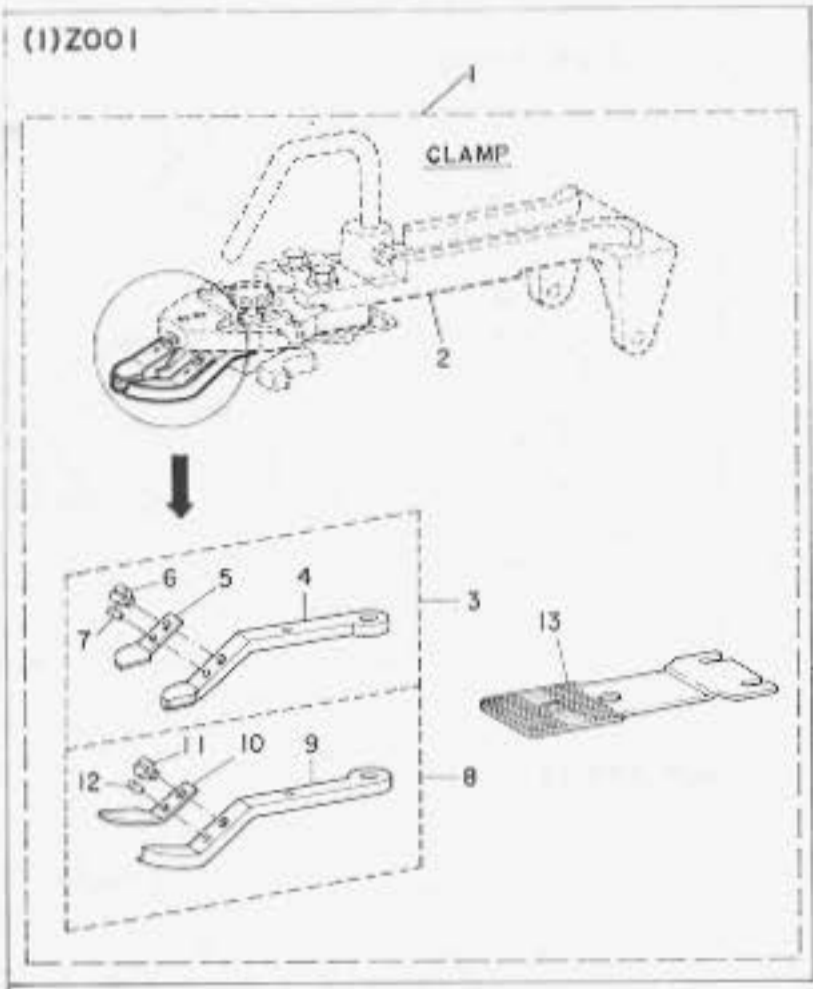

13. ATTACHMENT COMPONENTS FOR MODEL MB-372

MB-372アタッチメント関係

Ref. No.	Note	Part No.	Description	E.C.	品名	Amt. Req.
	注記	品番		変更年月		数量
(1) Z001 ATTACHMENT FOR LARGE BUTTONS						
1		MAZ-001000A0	Z001 asm.	A.10/75	Z001 (組)	1
2		D2547-372-CB0	Large button clamp asm.	A.10/75	大ボタンつまみ装置 (組)	(1)
3		D2555-372-CA0	Button clamp jaw lever (LEFT) asm.		大ボタン用ボタンつまみ足(左)(組)	(1)
4		D2555-372-C00	Button clamp jaw lever (LEFT)		大ボタン用ボタンつまみ足 (左)	(1)
5		D2556-372-C00	Button clamp plate spring (LEFT)		大ボタン用ボタンつまみ板バネ (左)	(1)
6		SS-7090520-TP	... Screw 9/64-40 L=4.5	D.6/85	SS-7090410-SP	-
		SS-7090410-SP	... Screw 9/64-40 L=3.5	A.6/85	つまみ足板バネ止ネジ	(1)
7		B2559-372-000	... Guide pin		つまみ足板バネガイドピン	(1)
8		D2557-372-CA0	Button clamp jaw lever (RIGHT) asm.		大ボタン用ボタンつまみ足(右)(組)	(1)
9		D2557-372-C00	Button clamp jaw lever (RIGHT)		大ボタン用ボタンつまみ足 (右)	(1)
10		D2558-372-C00	Button clamp plate spring (RIGHT)		大ボタン用ボタンつまみ板バネ (右)	(1)
11		SS-7090520-TP	... Screw 9/64-40 L=4.5	D.6/85	SS-7090410-SP	-
		SS-7090410-SP	... Screw 9/64-40 L=3.5	A.6/85	つまみ足板バネ止ネジ	(1)
12		B2559-372-000	... Guide pin		つまみ足板バネガイドピン	(1)
13		D2529-372-C00	Feed plate, large button		大ボタン用右押エ下板	(1)
(2) Z002 ATTACHMENT FOR MIDDLE BUTTONS						
1		D2529-372-B00	Feed plate, middle button		中ボタン用右押エ下板	1
(3) Z003 ATTACHMENT FOR SHANK BUTTONS						
1		B2401-372-0B0	Shank button clamp asm.		パールボタン用アタッチメント パールボタン付ケ (組)	1
2		SS-8120740-SP	Screw 3/16-28 L=7.0		パールボタン用押エ開キ棒止ネジ	(1)
3		B2411-372-000	Button clamp stud		ボタン押エ開キ棒	(1)
4		B2412-372-000	Button clamp block		ボタン開キ駒	(1)
5		SS-7110540-SP	Screw 11/64-40 L=5.0		パールボタン用ボタン開キ駒止ネジ	(1)
6		B2405-372-000	Button clamp lever		パールボタン押エ棒	(1)
7		SS-7110510-SP	Screw 11/64-40 L=5.0	D.1/77	SS-7110710-SP	-
		SS-7110710-SP	Screw 11/64-40 L=7.0	A.1/77	パールボタン押エ止ネジ	(1)
8		B2406-372-000	Shank button holding clamp		パールボタン押エ	(1)
9		SS-7110570-SP	Screw 11/64-40 L=4.8		パールボタン押エ棒止ネジ	(1)
10		B2402-372-000	Button clamp rotating shaft		パールボタン押エ回転軸	(1)
11		B2401-372-000	Button clamp bracket		パールボタン用つまみ足取付台	(1)
12		CS-072081A-SM	Thrust collar asm.	D.12/78	CS-072081A-SP	-
		CS-072081A-SP	Thrust collar asm.	A.12/78	パールボタン用スラストリング(組)	(1)
13		SS-8110410-TP	Screw 11/64-40 L=3.5		パールボタン用スラストリング止ネジ	(1)
14		B2404-372-000	Rotating shaft spring		ボタン押エ回転軸バネ	(1)
15		B2546-372-000	Button clamp lifting hook		つまみ装置引上げフック	(1)
16		SS-6111140-SP	Screw 11/64-40 L=11.0		パールボタン用つまみ足止ネジ	(1)
17		B2408-372-000	Shank button guard		パールボタン用つまみ足板バネ	(1)
18		B2419-372-A00	Shank button adapter (A)		パールボタン用つまみ足 (A)	(1)
19		B2419-372-B00	Shank button adapter (B)		パールボタン用つまみ足 (B)	(1)
20		SS-6110480-SP	Screw 11/64-40 L=4.3		パールボタン用布押エ下板止ネジ	(1)
21		B2410-372-000	Work support plate		パールボタン用布押エ下板	(1)
22		B2409-372-000	Button clamp feed plate		パールボタン用布押エ下板台	(1)
23		SS-9120910-TP	Screw 3/16-28 L=9.0		パールボタン用布押エ下板台止ネジ	(2)
24		WP-0501016-SD	Washer 5.0 x 10.5 x 1.0		パールボタン用布押エ下板台座金	(2)
25		SS-9621413-SP	Screw 3/16-32 L=13.5		パールボタン用つまみ足取付台ネジ	(2)
26		WP-0501016-SD	Washer 5.0 x 10.5 x 1.0		つまみ足取付台ネジ座金	(2)
27		B2542-372-000	Button clamp holder		つまみ装置取付台	(1)
28		SS-7150940-SP	Screw (A) 15/64-28 L=9.0		つまみ装置引上げフック止ネジ (A)	(1)
29		SS-8150510-TP	Screw (B) 15/64-28 L=4.7	D.2/85	SS-7150940-SP	-
		SS-7150940-SP	Screw 15/64-28 L=9.0	A.2/85	つまみ装置引上げフック止ネジ	(1)
30	04	B2410-372-00A	Work support plate (A)	A.12/74	パールボタン用布押エ下板 (A)	1
31	04	B2410-372-00B	Work support plate (B)	A.12/74	パールボタン用布押エ下板 (B)	1
32	04	B2410-372-00C	Work support plate (C)	A.12/74	パールボタン用布押エ下板 (C)	1
33	04	B2410-372-00D	Work support plate (D)	A.12/74	パールボタン用布押エ下板 (D)	1
(4) Z004 ATTACHMENT FOR FIRST PROCESS OF WRAPPED-AROUND BUTTONS						
1		B2447-372-0A0	Wrapped-around button foot asm.	A.10/75	根巻第一工程用アタッチメント 根巻用足 (組)	1
2		B2447-372-000	Wrapped-around button foot		根巻用足	(1)
3		WP-0501016-SD	... Washer 5.0 x 10.5 x 1.0		根巻用足止ネジ座金	(1)
4		SS-9120910-TP	... Screw 3/16-28 L=9.0		根巻用足止ネジ	(1)
5		B2446-372-000	... Guide pin		根巻用足ガイドピン	(1)
* This attachment can be also used for MB-373.						
* このアタッチメントはMB-373にも使用できます。						
(5) Z005 ATTACHMENT FOR SECOND PROCESS OF WRAPPED-AROUND BUTTONS						
1		B2440-372-0A0	Wrapped-around button clamp asm.		根巻第二工程用アタッチメント 根巻第二工程アタッチメント (組)	1
2		B2440-372-000	... Feed plate		根巻用金具取付台	(1)
3		B2441-372-0A0	... Guide (LARGE) asm.		根巻用金具(大)(組)	(1)
4		B2442-372-0A0	... Guide (MIDDLE) asm.		根巻用金具(中)(組)	(1)
5		SS-6110480-SP	... Screw 11/64-40 L=4.3		根巻用金具取付ネジ	(1)

Note (注記) 04 Special order parts for MB-372 MB-372用特別注文部品

(6)Z007

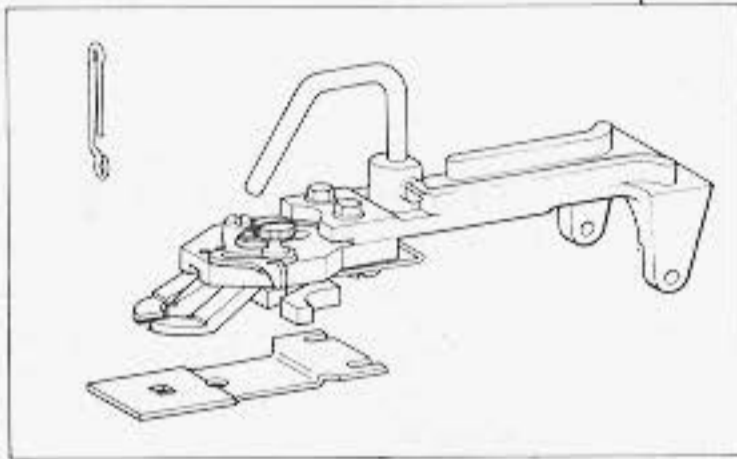

(7)Z008

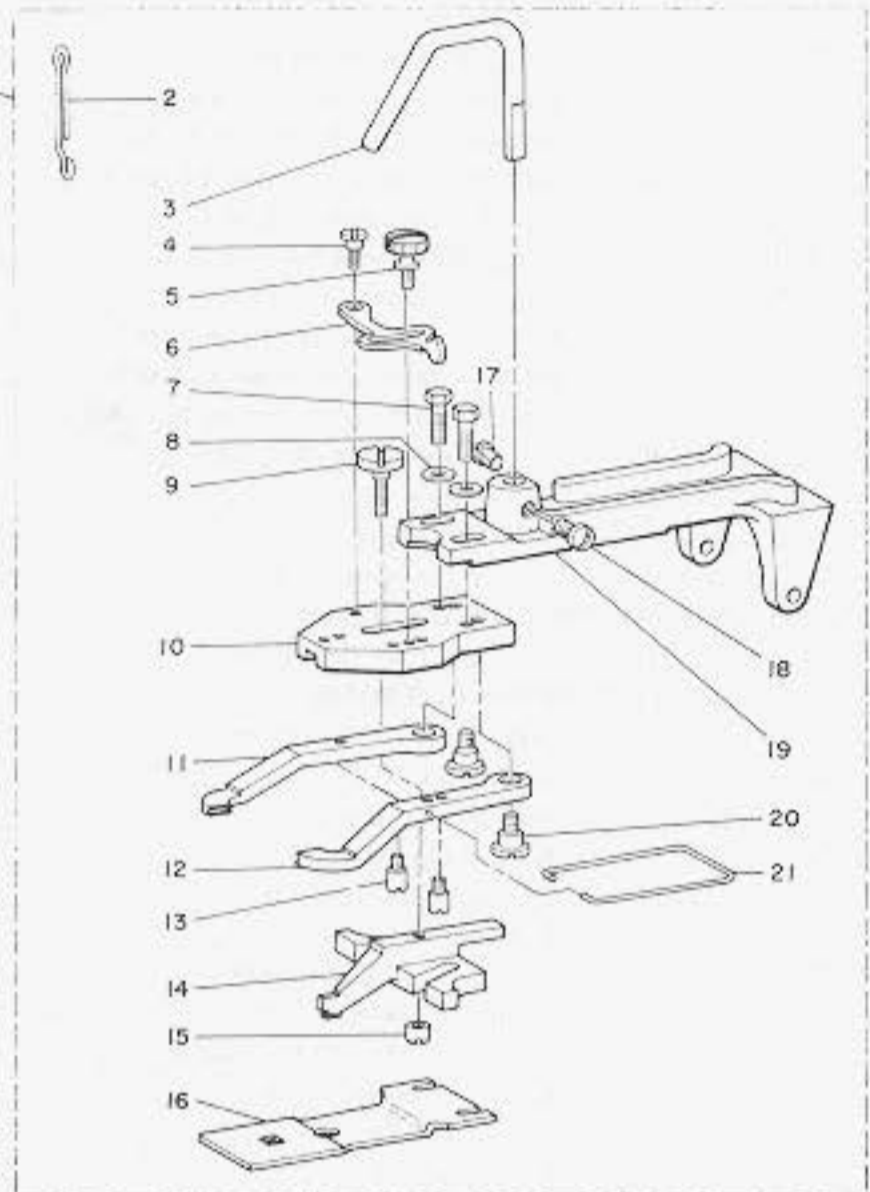
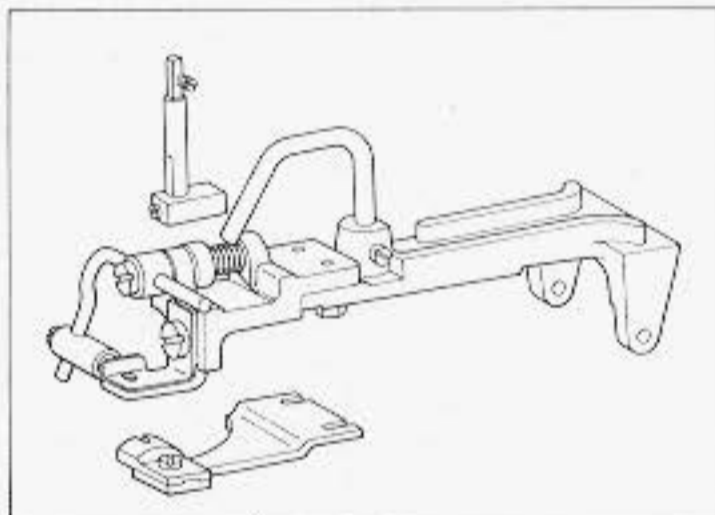

(8)Z009

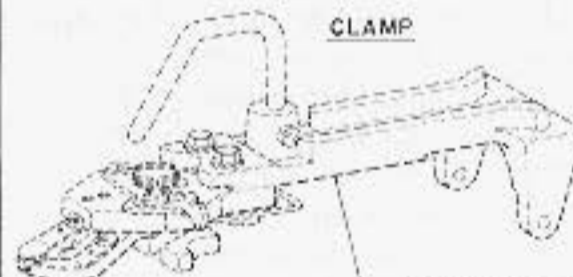

B2547-372-0B0 (SMALL BUTTON)
D2547-372-CB0 (LARGE BUTTON)

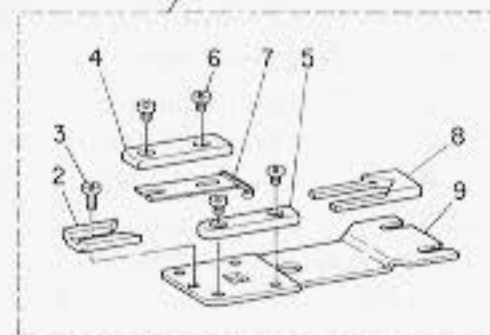
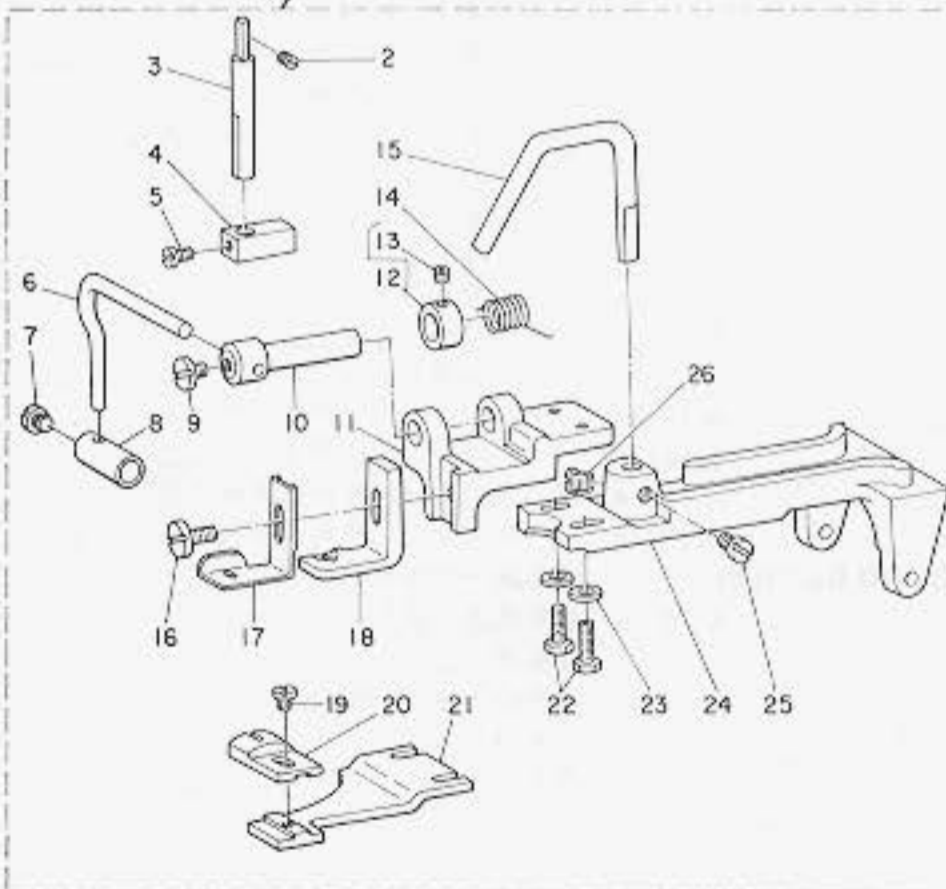

13. ATTACHMENT COMPONENTS FOR MODEL MB-372

MB-372アタッチメント関係

Ref. No.	Note	Part No.	Description	E.C.	Amt. Req.
	注記	品番		変更年月	数量
(6) 2007 ATTACHMENT FOR SNAPS					
1		B2552-372-BA0	Snap clamp asm.		1
2		B3107-372-B00	Thread guide No.3, snap clamp		(1)
3		B2546-372-000	Button calmp lifting hook		(1)
4		SD-0550181-SP	Hinge screw (B) D=5.50 H=1.8		(1)
5		B2549-372-000	Clamp screw (A)		(1)
6		B2548-372-000	Button clamp stop lever		(1)
7		SS-9621413-SP	Screw 3/16-32 L=13.5		(2)
8		WP-0501016-SD	Washer 5.0 x 10.5 x 1.0		(2)
9		SD-0550301-SP	Hinge screw (A) D=5.50 H=3.0		(1)
10		B2547-372-000	Button clamp jaw lever holder		(1)
11		B2555-372-B00	Snap clamp jaw lever (LEFT)		(1)
12		B2557-372-B00	Snap clamp jaw lever (RIGHT)		(1)
13		B2560-372-000	Button clamp stop pin		(2)
14		B2552-372-B00	Snap clamp slide guide		(1)
15		B2553-372-000	... Screw (B)		(1)
16		B2529-372-B00	Snap clamp feed plate		(1)
17		SS-8150510-TP	Screw (B) 15/64-28 L=4.7	D.2/85	-
		SS-7150940-SP	Screw 15/64-28 L=9.0	A.2/85	(1)
18		SS-7150940-SP	Screw (A) 15/64-28 L=9.0		(1)
19		B2542-372-000	Button clamp holder		(1)
20		SD-0640391-TP	Hinge screw D=6.35 H=3.9		(2)
21		B2561-372-000	Button clamp spring		(1)
(7) 2008 ATTACHMENT FOR METAL BUTTONS					
1		B2420-372-0A0	Metal button clamp asm.		1
2		SS-8120740-SP	Screw 3/16-28 L=7.0		(1)
3		B2411-372-000	Button clamp stud		(1)
4		B2412-372-000	Button clamp block	C. 1/82	(1)
5		SS-7110540-SP	Screw 11/64-40 L=5.0		(1)
6		B2405-372-000	Button clamp lever		(1)
7		SS-7110510-SP	Screw 11/64-40 L=5.0	D.1/77	-
		SS-7110710-SP	Screw 11/64-40 L=7.0	A.1/77	(1)
8		B2406-372-000	Shank button holding clamp		(1)
9		SS-7110570-SP	Screw 11/64-40 L=4.8		(1)
10		B2402-372-000	Button clamp rotating shaft		(1)
11		B2401-372-000	Button clamp bracket		(1)
12		CS-072081A-SM	Thrust collar asm.	D.12/78	-
		CS-072081A-SP	Thrust collar asm.	A.12/78	(1)
13		SS-8110410-TP	Screw 11/64-40 L=3.5		(1)
14		B2404-372-000	Rotating shaft spring		(1)
15		B2546-372-000	Button clamp lifting hook		(1)
16		SS-6111140-SP	Screw 11/64-40 L=11.0		(1)
17		B2422-372-000	Metal button guard		(1)
18		B2421-372-000	Metal button adapter		(1)
19		SS-6110480-SP	Screw 11/64-40 L=4.3		(1)
20		B2423-372-000	Metal button work support plate		(1)
21		B2409-372-000	Button clamp feed plate		(1)
22		SS-9621413-SP	Screw 3/16-32 L=13.5		(2)
23		WP-0501016-SD	Washer 5.0 x 10.5 x 1.0		(2)
24		B2542-372-000	Button clamp holder		(1)
25		SS-7150940-SP	Screw (A) 15/64-28 L=9.0		(1)
26		SS-8150510-TP	Screw (B) 15/64-28 L=4.7	D.2/85	-
		SS-7150940-SP	Screw 15/64-28 L=9.0	A.2/85	(1)
(8) 2009 ATTACHMENT FOR REINFORCING-STAY BUTTONS					
1		MAT-60901ZA0	Feed plate asm. reinforcing-stay button		1
2		MAT-60905Z00	... Holder (B)	D.4/75	-
		MAT-60905Z00-A	... Holder (B)	A.4/75	(1)
3		SS-4080310-SP	... Screw 1/8-44 L=3.4		(1)
4		MAT-60903Z00	... Guide (B)	D.4/75	-
		MAT-60903Z00-A	... Guide (B)	A.4/75	(1)
5		MAT-60902Z00	... Guide (A)		(1)
6		SS-4080310-SP	... Screw 1/8-44 L=3.4	D.4/75	-
		SS-6080410-SP	... Screw 1/8-44 L=4.0	A.4/75	(4)
7		MAZ-00906000	... Presser spring	A.4/75	(1)
8		MAT-60904Z00	... Holder (A)	D.4/75	-
		MAT-60904Z00-A	... Holder (A)	A.4/75	(1)
9		MAT-60901Z00	... Feed plate		(1)

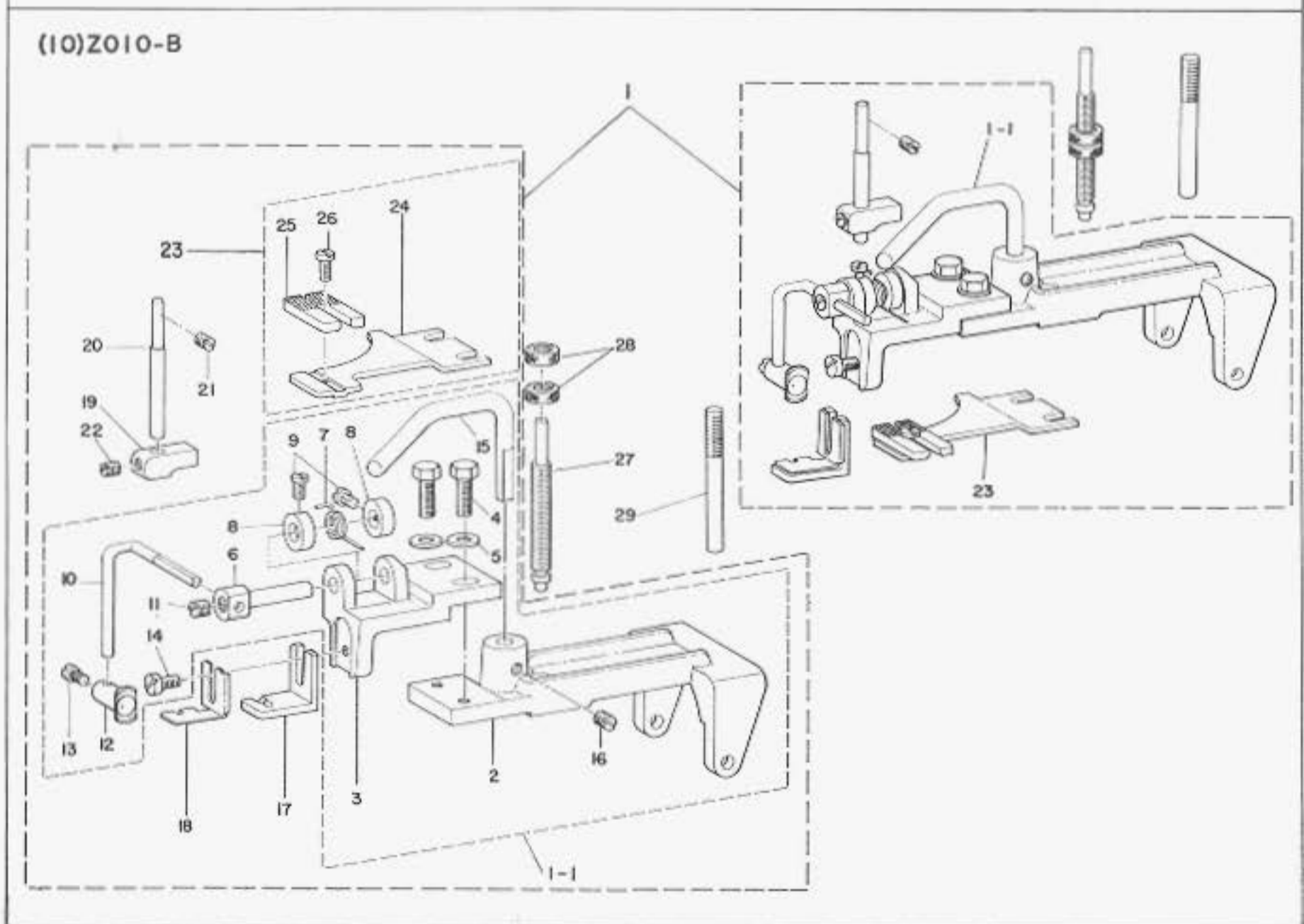
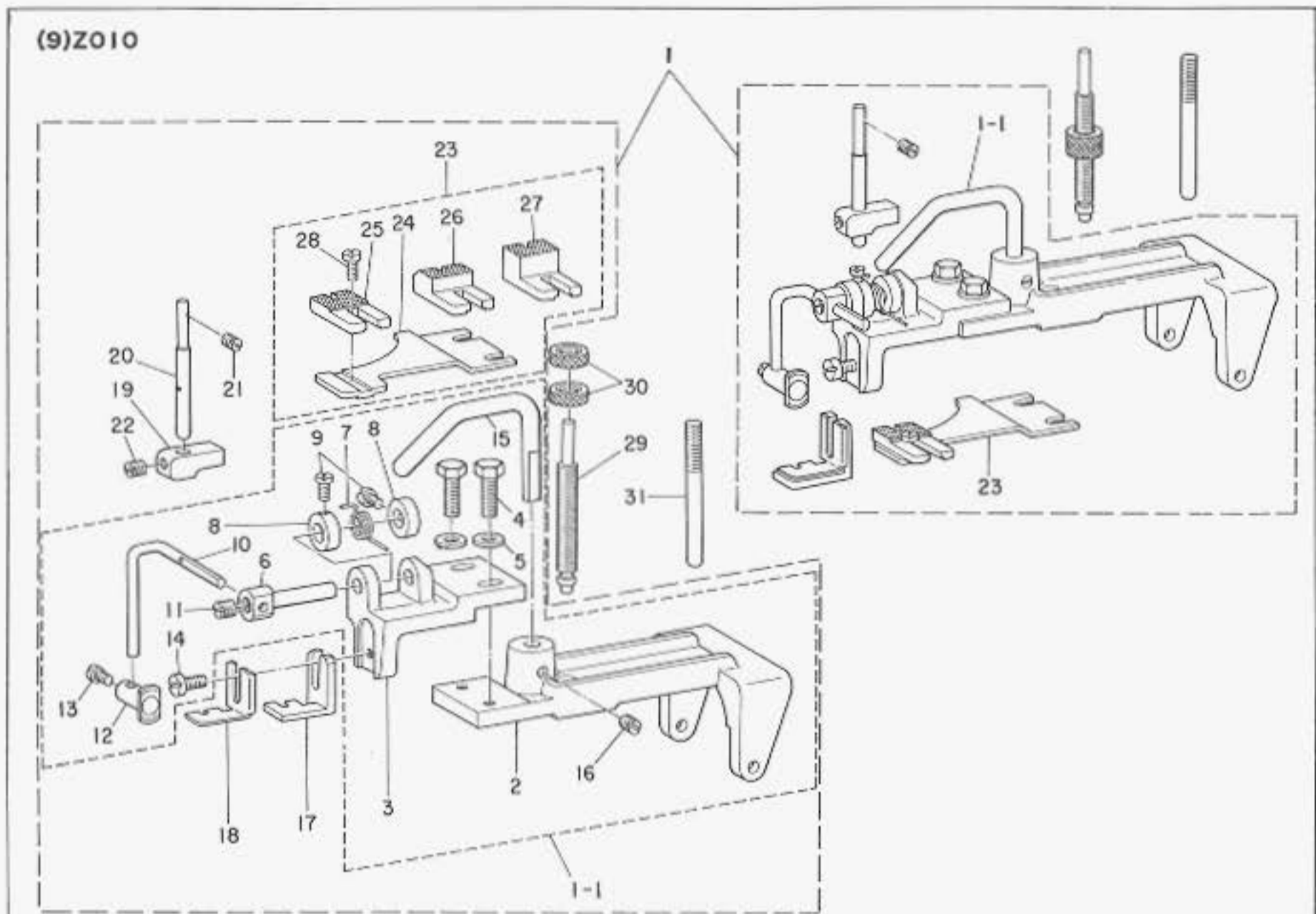

13. ATTACHMENT COMPONENTS FOR MODEL MB-372

MB-372アタッチメント関係

Ref. No.	Note	Part No.	Description	E.C.	品名	Amt Req
	注記	品番		変更年月		数量
(9) Z010 ATTACHMENT FOR LOUIS TYPE SHANK BUTTONS						
1		MAZ-010000A0	Shank button clamp asm. (Z010)	A.3/76	ルイスタイプパールボタン用アタッチメント Z010 (組)	1
1-1		B2401-372-LA0	Shank button clamp (L) asm.		パールボタン取付具(L)(組)	1
2		B2542-372-L00	Button clamp holder (L)		ツマミ装置取付台(L)	(1)
3		B2401-372-L00	Button clamp bracket (L)		パールボタン用ツマミ足取付台(L)	(1)
4		SS-9621413-SP	... Screw 3/16-32 L=13.5		ツマミ足取付台(L)止ネジ	(2)
5		B2425-372-L00	... Washer 5.2x9.6x1.0	D.5/79	WP-0501016-SD	-
		WP-0501016-SD	... Washer 5.0x10.5x1.0	A.5/79	ツマミ足取付台(L)座金	(2)
6		B2402-372-L00	Button clamp rotating shaft (L)		パールボタン押エ回転軸(L)	(1)
7		B2404-372-L00	... Spring (L)		ボタン押エ回転軸バネ(L)	(1)
8		B2426-372-L00	Thrust collar (L) D=6.35 W=5.6		パールボタン用スラストリング(L)	(2)
9		B2427-372-L00	... Screw		パールボタン用スラストリング(L)止ネジ	(2)
10		B2405-372-L00	Button clamp lever (L)		パールボタン押エ棒(L)	(1)
11		B2429-372-L00	... Screw 3/16-32 L=5.0		パールボタン押エ棒(L)止ネジ	(1)
12		B2406-372-L00	Shank button holding clamp (L)		パールボタン押エ(L)	(1)
13		B2428-372-L00	... Screw		パールボタン押エ(L)止ネジ	(1)
14		B2430-372-L00	Screw		パールボタン用ツマミ足(L)止ネジ	(1)
15		B2546-372-L00	Button clamp lifting hook (L)		ツマミ装置引上げフック(L)	(1)
16		B2431-372-L00	... Screw 7/32-32 L=6.4		ツマミ装置引上げフック(L)止ネジ	(1)
17		B2419-372-L00	Shank button adapter (L)		パールボタン用ツマミ足(L)	1
18		B2408-372-L00	Shank button guard (L)		パールボタン用ツマミ足板バネ(L)	1
19		B2412-372-L00	Button clamp block (L)		ボタン押エ開キ駒(L)	1
20		B2411-372-L00	Button clamp stud (L)		ボタン押エ開キ棒(L)	1
21		SS-8120740-SP	Screw 3/16-28 L=7.0		ボタン押エ開キ棒(L)止ネジ	1
22		B2433-372-L00	Screw 3/16-32 L=9.2		ボタン押エ開キ駒(L)止ネジ	1
23		B2409-372-LA0	Button clamp feed plate (L) asm.		パールボタン用布押エ下板台(L)(組)	1
24		B2409-372-L00	Button clamp feed plate (L)		パールボタン用布押エ下板台(L)	(1)
25		B2410-372-L0A	Work support plate (L) (SMALL)		パールボタン用布押エ下板(L)(小)	(1)
26		B2410-372-L0B	Work support plate (L) (MIDDLE)		パールボタン用布押エ下板(L)(中)	(1)
27		B2410-372-L0C	Work support plate (L) (LARGE)		パールボタン用布押エ下板(L)(大)	(1)
28		B2434-372-L00	... Screw 1/8-44 L=6.4		パールボタン用布押エ下板(L)止ネジ	(1)
29		B2544-372-L00	Pressure adjusting bar (L)		押エ圧力調節棒(L)	1
30		B2435-372-L00	Pressure adjusting nut (L)		押エ圧力調節ナット(L)	2
31		B2543-372-L00	Stopper pin (L)		ツマミ装置ストッパーピン(L)	1
(10) Z010-B ATTACHMENT FOR LOUIS TYPE SHANK BUTTONS						
1		MAZ-010001A0	Shank button clamp asm. (Z010B)	A.3/76	Z010B (組)	1
1-1		B2401-372-BA0	Shank button clamp (B) asm.		パールボタン取付具(B)(組)	1
2		B2542-372-L00	Button clamp holder (L)		ツマミ装置取付台(L)	(1)
3		B2401-372-L00	Button clamp bracket (L)		パールボタン用ツマミ足取付台(L)	(1)
4		SS-9621413-SP	... Screw 3/16-32 L=13.5		ツマミ足取付台(L)止ネジ	(2)
5		B2425-372-L00	... Washer 5.2x9.6x1.0	D.5/79	WP-0501016-SD	-
		WP-0501016-SD	... Washer 5.0x10.5x1.0	A.5/79	ツマミ足取付台(L)座金	(2)
6		B2402-372-L00	Button clamp rotating shaft (L)		パールボタン押エ回転軸(L)	(1)
7		B2404-372-L00	... Spring (L)		ボタン押エ回転軸バネ(L)	(1)
8		B2426-372-L00	Thrust collar (L) D=6.35 W=5.6		パールボタン用スラストリング(L)	(2)
9		B2427-372-L00	... Screw		パールボタン用スラストリング(L)止ネジ	(2)
10		B2405-372-L00	Button clamp lever (L)		パールボタン押エ棒(L)	(1)
11		B2429-372-L00	... Screw 3/16-32 L=5.0		パールボタン押エ棒(L)止ネジ	(1)
12		B2406-372-B00	Shank button holding clamp (B)		パールボタン押エ(B)	(1)
13		SS-7110720-SP	Screw 11/64-40 L=7.0		パールボタン押エ(B)止ネジ	(1)
14		B2430-372-L00	Screw		パールボタン用ツマミ足(L)止ネジ	(1)
15		B2546-372-L00	Button clamp lifting hook (L)		ツマミ装置引上げフック(L)	(1)
16		B2431-372-L00	... Screw 7/32-32 L=6.4		ツマミ装置引上げフック(L)止ネジ	(1)
17		B2419-372-C00	Shank button adapter (C)		パールボタン用ツマミ足(C)	1
18		B2408-372-B00	Shank button guard (B)		パールボタン用ツマミ足板バネ(B)	1
19		B2412-372-L00	Button clamp block (L)		ボタン押エ開キ駒(L)	1
20		B2411-372-L00	Button clamp stud (L)		ボタン押エ開キ棒(L)	1
21		SS-8120740-SP	Screw 3/16-28 L=7.0		ボタン押エ開キ棒(L)止ネジ	1
22		B2433-372-L00	Screw 3/16-32 L=9.2		ボタン押エ開キ駒(L)止ネジ	1
23		B2409-372-BA0	Button clamp feed plate (B) asm.		パールボタン用布押エ下板台(B)(組)	1
24		B2409-372-L00	Button clamp feed plate (L)		パールボタン用布押エ下板台(L)	(1)
25		B2410-372-B00	Work support plate (B)		パールボタン用布押エ下板(B)	(1)
26		B2434-372-L00	... Screw 1/8-44 L=6.4		パールボタン用布押エ下板(L)止ネジ	(1)
27		B2544-372-L00	Pressure adjusting bar (L)		押エ圧力調節棒(L)	1
28		B2435-372-L00	Pressure adjusting nut (L)		押エ圧力調節ナット(L)	2
29		B2543-372-L00	Stopper pin (L)		ツマミ装置ストッパーピン(L)	1

* This attachment is used in common with MB-372-16.

* このアタッチメントはMB-372-16のミシンと共用します。

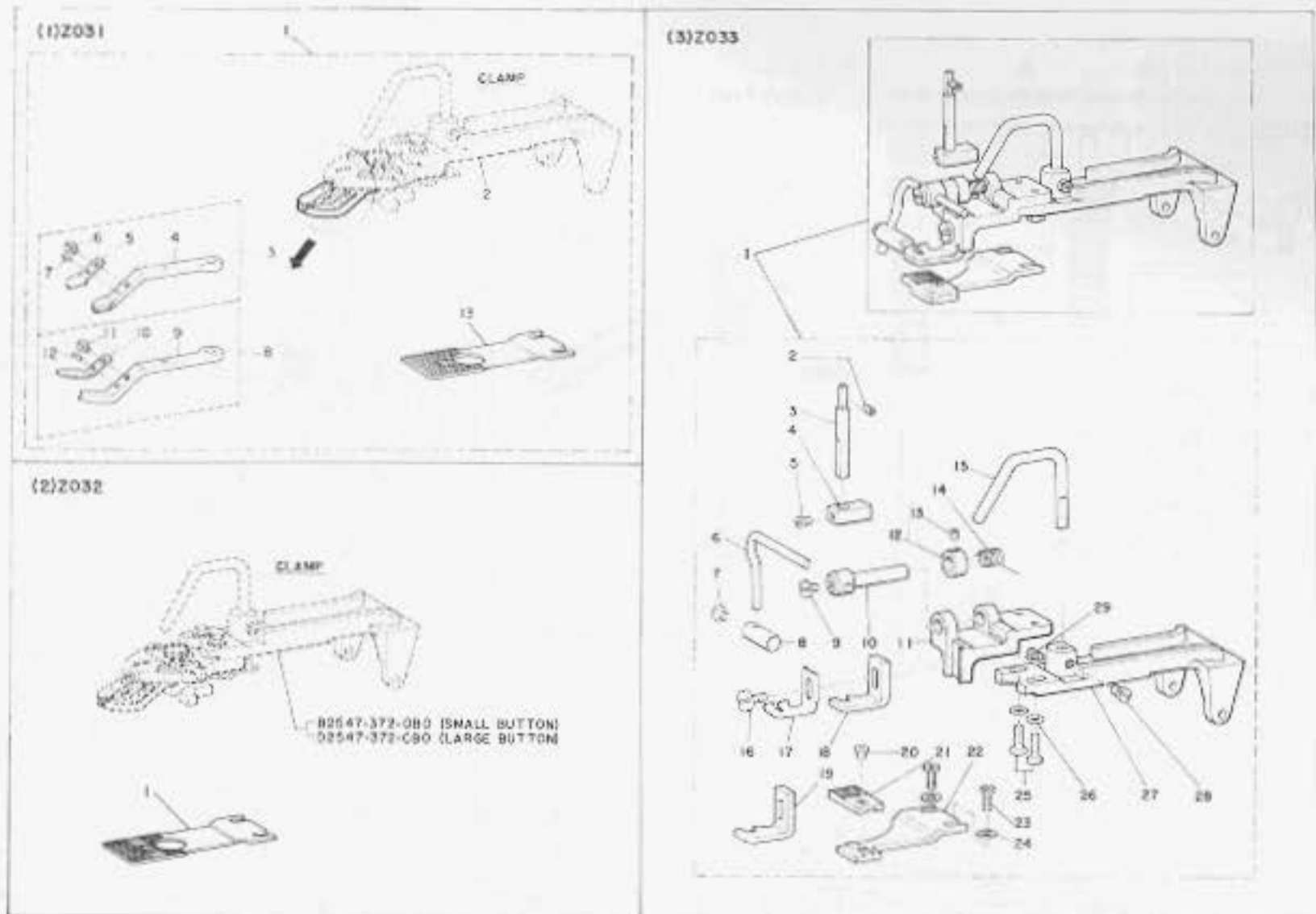

Ref. No.	Note	Part No.	Description	E.C.	品名	Amt. Req. 数量
(1) Z031 ATTACHMENT FOR LARGE BUTTONS						
1		MAZ-031000A0	Z031 asm.	A.10/75	Z031 (組)	1
2		D2547-372-CB0	Large button clamp asm.	A.10/75	大ボタン用ボタンつまみ装置 (組)	(1)
3		D2555-372-CA0	Button clamp jaw lever (LEFT) asm.		大ボタン用ボタンつまみ足 (左)(組)	(1)
4		D2555-372-C00	Button clamp jaw lever (LEFT)		大ボタン用ボタンつまみ足 (左)	(1)
5		D2556-372-C00	Button clamp plate spring (LEFT)		大ボタン用ボタンつまみ板バネ (左)	(1)
6		SS-7090520-TP	Screw 9/64-40 L=4.5	D.6/85	SS-7090410-SP	-
		SS-7090410-SP	Screw 9/64-40 L=3.5	A.6/85	つまみ足板バネ止ネジ	(1)
7		B2559-372-000	Guide pin		つまみ足板バネガイドピン	(1)
8		D2557-372-CA0	Button clamp jaw lever (RIGHT) asm.		大ボタン用ボタンつまみ足 (右)(組)	(1)
9		D2557-372-C00	Button clamp jaw lever (RIGHT)		大ボタン用ボタンつまみ足 (右)	(1)
10		D2558-372-C00	Button clamp plate spring (RIGHT)		大ボタン用ボタンつまみ板バネ (右)	(1)
11		SS-7090520-TP	Screw 9/64-40 L=4.5	D.6/85	SS-7090410-SP	-
		SS-7090410-SP	Screw 9/64-40 L=3.5	A.6/85	つまみ足板バネ止ネジ	(1)
12		B2559-372-000	Guide pin	C.11/75	B2529-372-000	(1)
13		D2529-373-C00	Feed plate, large button		大ボタン用右押エ下板	(1)
(2) Z032 ATTACHMENT FOR MIDDLE BUTTONS						
1		D2529-373-B00	Feed plate, middle button		中ボタン用アタッチメント	1
(3) Z033 ATTACHMENT FOR SHANK BUTTONS						
1		B2401-373-0B0	Shank button clamp asm.		パールボタン用アタッチメント	1
2		SS-8120740-SP	Screw 3/16-28 L=7.0		パールボタン付ケ (組)	(1)
3		B2411-372-000	Button clamp stud		パールボタン用押エ開キ棒止ネジ	(1)
4		B2412-372-000	Button clamp block		ボタン押エ開キ棒	(1)
5		SS-7110540-SP	Screw 11/64-40 L=5.0		ボタン開キ軸	(1)
6		B2405-372-000	Button clamp lever		パールボタン用ボタン開キ軸止ネジ	(1)
7		SS-7110510-SP	Screw 11/64-40 L=5.0	D.1/77	SS-7110710-SP	-
		SS-7110710-SP	Screw 11/64-40 L=7.0	A.1/77	パールボタン押エ止ネジ	(1)
8		B2406-372-000	Shank button holding clamp		パールボタン押エ	(1)
9		SS-7110570-SP	Screw 11/64-40 L=4.8		パールボタン押エ棒止ネジ	(1)
10		B2402-372-000	Button clamp rotating shaft		パールボタン押エ回転軸	(1)
11		B2401-372-000	Button clamp bracket		パールボタン用つまみ足取付台	(1)
12		CS-072081A-SM	Thrust collar asm.	D.12/78	CS-072081A-SP	-
		CS-072081A-SP	Thrust collar asm.	A.12/78	パールボタン用スラストリング(組)	(1)
13		SS-8110410-TP	Screw 11/64-40 L=3.5		パールボタン用スラストリング止ネジ	(1)
14		B2404-372-000	Rotating shaft spring		ボタン押エ回転軸バネ	(1)
15		B2546-372-000	Button clamp lifting hook		つまみ装置引上げフック	(1)
16		SS-6111140-SP	Screw 11/64-40 L=11.0		パールボタン用つまみ足止ネジ	(1)
17		B2408-372-000	Shank button guard		パールボタン用つまみ足板バネ	(1)
18		B2419-372-A00	Shank button adapter (A)		パールボタン用つまみ足 (A)	(1)
19		B2419-372-B00	Shank button adapter (B)		パールボタン用つまみ足 (B)	(1)
20		SS-6110480-SP	Screw 11/64-40 L=4.3		パールボタン用右押エ下板止ネジ	(1)
21		B2410-372-000	Work support plate		パールボタン用右押エ下板	(1)
22		B2470-373-000	Button clamp feed plate		パールボタン用右押エ下板台	(1)
23		SS-9120910-TP	Screw 3/16-28 L=9.0		パールボタン用右押エ下板台止ネジ	(2)
24		WP-0501016-SD	Washer 5.0 x 10.5 x 1.0		パールボタン用右押エ下板台座金	(2)
25		SS-9621413-SP	Screw 3/16-32 L=13.5		パールボタン用つまみ足取付台ネジ	(2)
26		WP-0501016-SD	Washer 5.0 x 10.5 x 1.0		つまみ足取付台ネジ座金	(2)
27		B2542-372-000	Button clamp holder		つまみ装置取付台	(1)
28		SS-7150940-SP	Screw (A) 15/64-28 L=9.0		つまみ装置引上げフック止ネジ (A)	(1)
29		SS-8150510-TP	Screw (B) 15/64-28 L=4.7	D.2/85	SS-7150940-SP	-

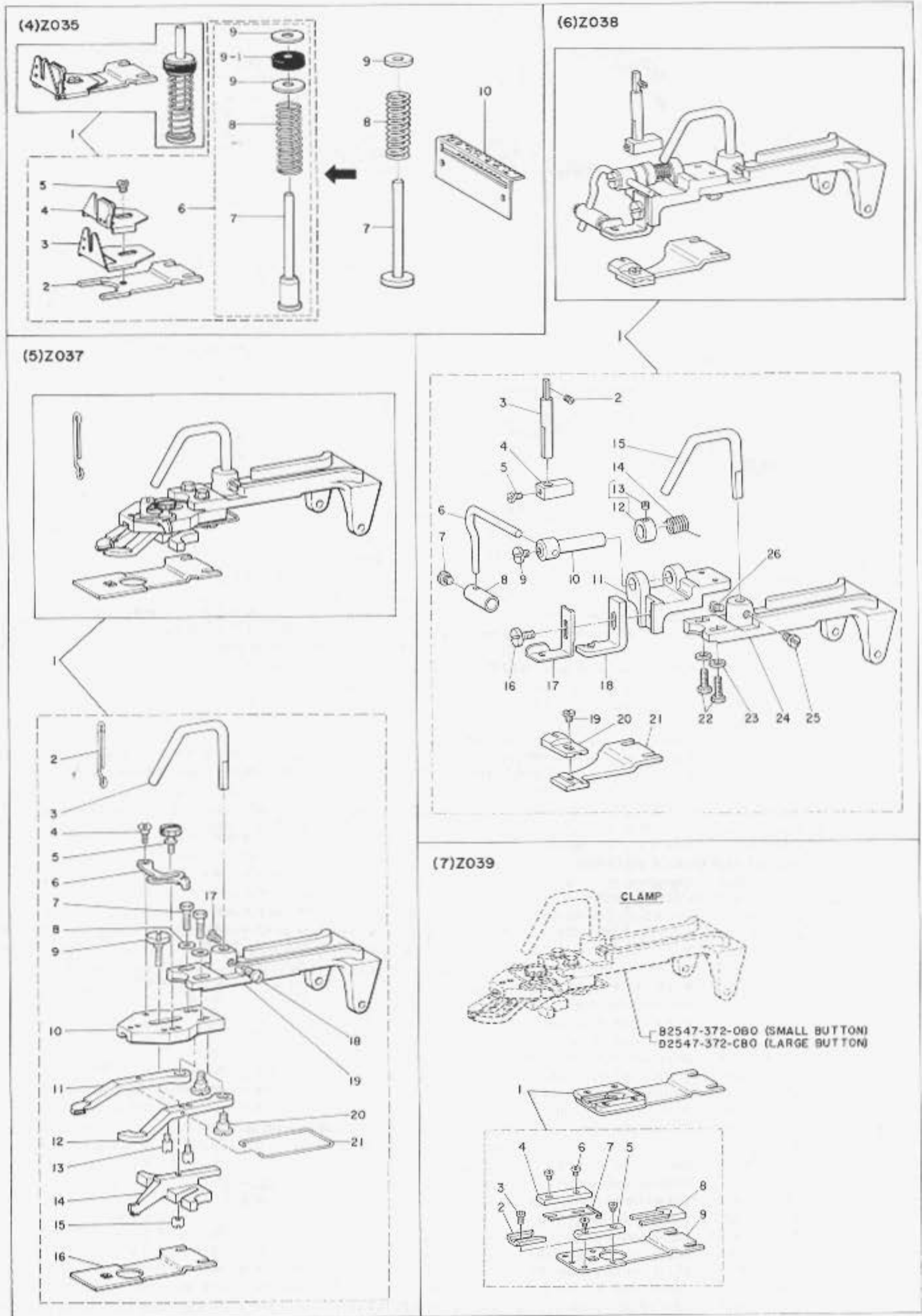

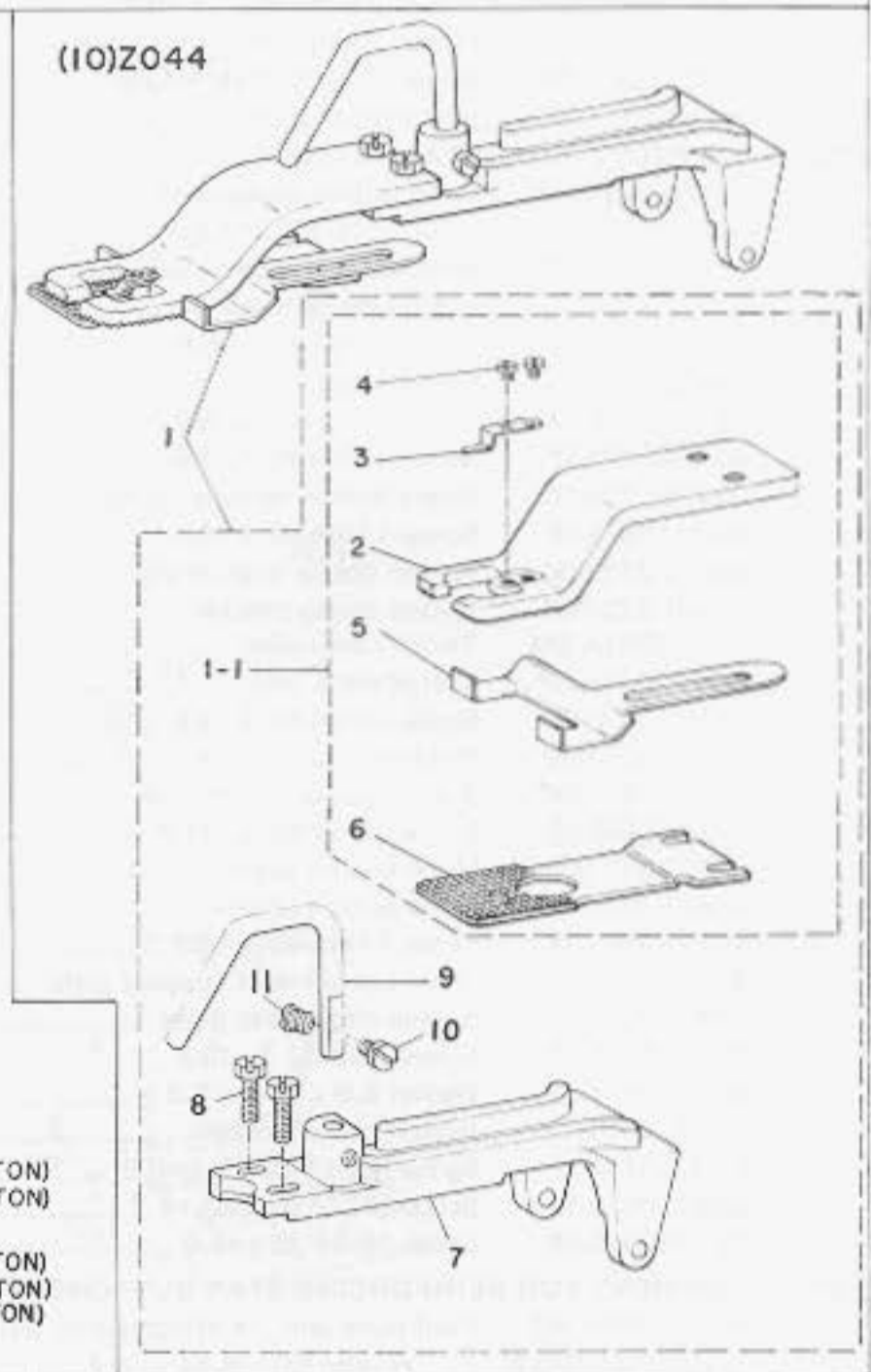
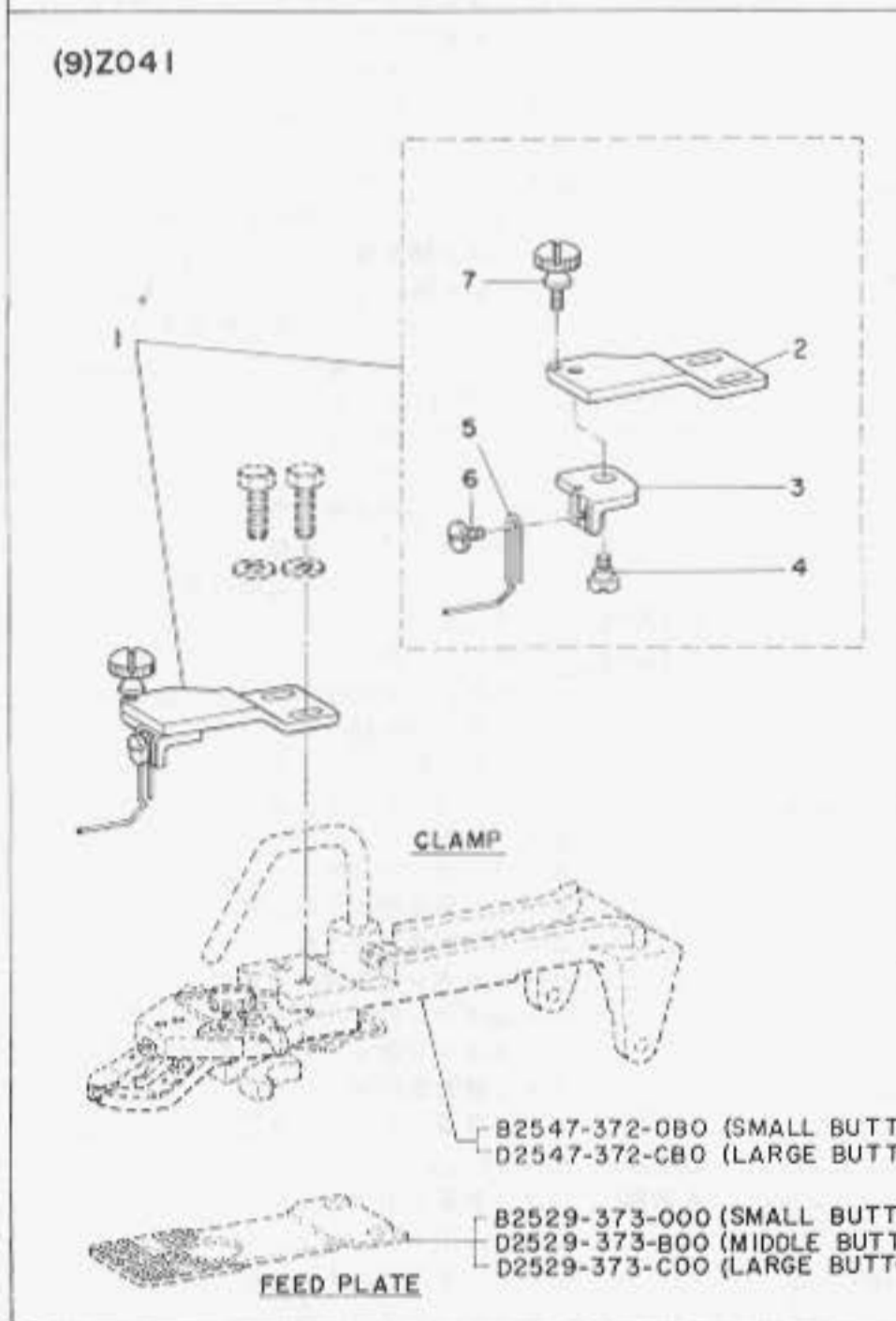
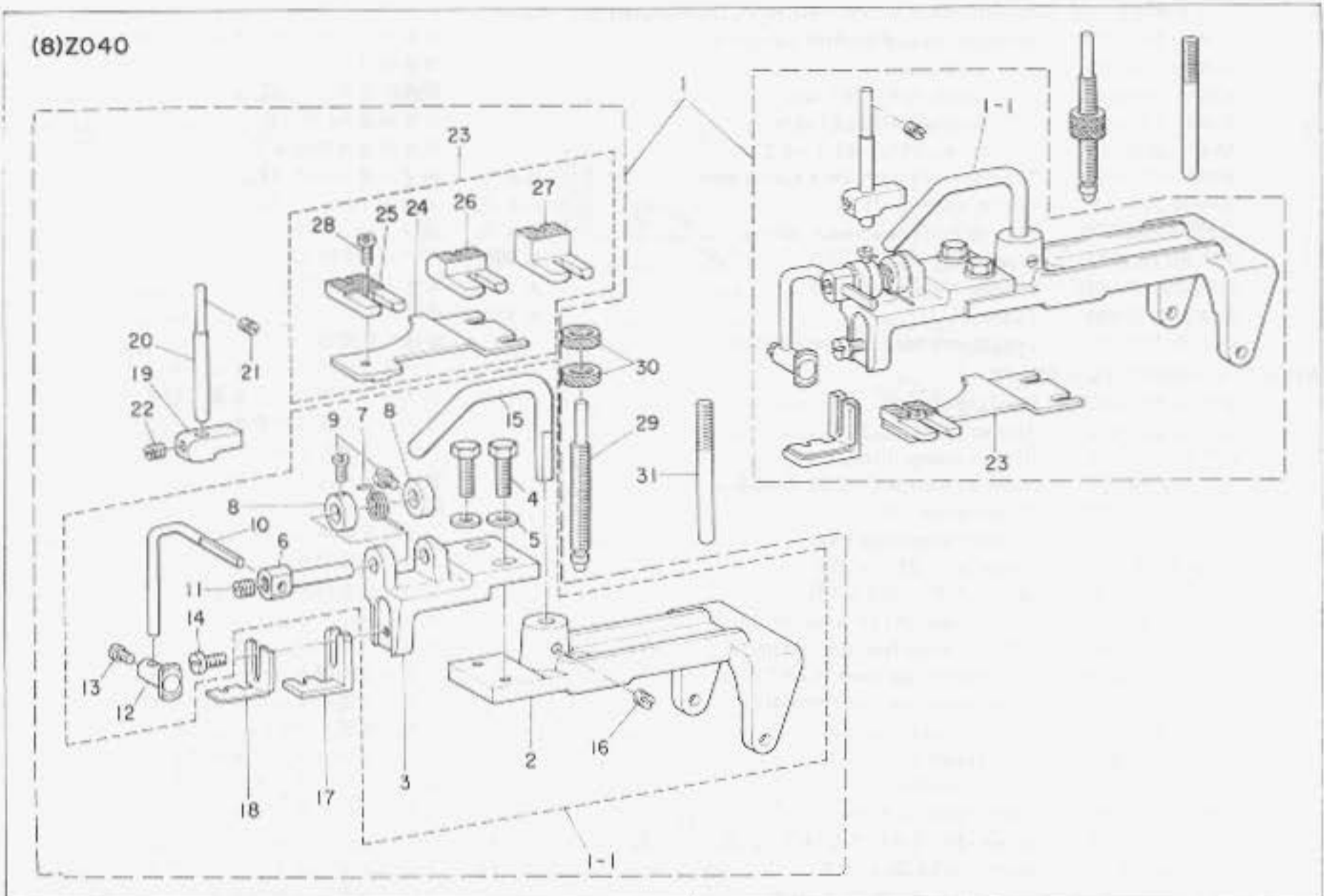

Ref. No.	Note	Part No.	Description	E.C.	品名	Am. Ref. 数
	注記	品番		変更年月		
(8) Z040 ATTACHMENT FOR LOUIS TYPE SHANK BUTTONS						ルイスタイプパールボタン用アタッチメント
1		MAZ-040000A0	Z040 asm. (Ref.No.1-1~22, 24, 25, 28)	A.3/76	Z040 (組)	1
1-1		B2401-372-LA0	Shank button clamp (L) asm.		パールボタン取付具(L)(組)	1
2		B2542-372-L00	Button clamp holder (L)		ツマミ装置取付台(L)	(1)
3		B2401-372-L00	Button clamp bracket (L)		パールボタン用ツマミ足取付台(L)	(1)
4		SS-9621413-SP	Screw 3/16-32 L=13.5		ツマミ足取付台(L)止ネジ	(2)
5		B2425-372-L00	Washer 5.2x9.6x1.0	D.5/79	WP-0501016-SD	
		WP-0501016-SD	Washer 5.0x10.5x1.0	A.5/79	ツマミ足取付台(L)座金	(2)
6		B2402-372-L00	Button clamp rotating shaft (L)		パールボタン押エ回転軸(L)	(1)
7		B2404-372-L00	Spring (L)		ボタン押エ回転軸バネ(L)	(1)
8		B2426-372-L00	Thrust collar (L) D=6.35 W=5.6		パールボタン用スラストリング(L)	(2)
9		B2427-372-L00	Screw		パールボタン用スラストリング(L)止ネジ	(2)
10		B2405-372-L00	Button clamp lever (L)		パールボタン用押エ棒(L)	(1)
11		B2429-372-L00	Screw 3/16-32 L=5.0		パールボタン用押エ棒(L)止ネジ	(1)
12		B2406-372-L00	Shank button holding clamp (L)		パールボタン押エ(L)	(1)
13		B2428-372-L00	Screw		パールボタン押エ(L)止ネジ	(1)
14		B2430-372-L00	Screw		パールボタン用ツマミ足(L)止ネジ	(1)
15		B2546-372-L00	Button clamp lifting hook (L)		ツマミ装置引上げフック(L)	(1)
16		B2431-372-L00	Screw 7/32-32 L=6.4		ツマミ装置引上げフック(L)止ネジ	(1)
17		B2419-372-L00	Shank button adapter (L)		パールボタン用ツマミ足(L)	1
18		B2408-372-L00	Shank button guard (L)		パールボタン用ツマミ足板バネ(L)	1
19		B2412-372-L00	Button clamp block (L)		ボタン押エ開キ駒(L)	1
20		B2411-372-L00	Button clamp stud (L)		ボタン押エ開キ棒(L)	1
21		SS-8120740-SP	Screw 3/16-28 L=7.0		ボタン押エ開キ棒(L)止ネジ	1
22		B2433-372-L00	Screw 3/16-32 L=9.2		ボタン押エ開キ駒(L)止ネジ	1
23		B2409-373-LA0	Button clamp feed plate (L) asm.		パールボタン用布押エ下板台(L)(組)	1
24		B2409-373-L00	Button clamp feed plate (L)		パールボタン用布押エ下板台(L)	(1)
25		B2410-372-L0A	Work support plate (L) (SMALL)		パールボタン用布押エ下板(L)(小)	(1)
26		B2410-372-L0B	Work support plate (L) (MIDDLE)		パールボタン用布押エ下板(L)(中)	(1)
27		B2410-372-L0C	Work support plate (L) (LARGE)		パールボタン用布押エ下板(L)(大)	(1)
28		B2434-372-L00	Screw 1/8-44 L=6.4		パールボタン用布押エ下板(L)止ネジ	(1)
29		B2544-372-L00	Pressure adjusting bar (L)		押エ圧力調節棒(L)	1
30		B2435-372-L00	Pressure adjusting nut (L)		押エ圧力調節ナット(L)	2
31		B2543-372-L00	Stopper pin (L)		ツマミ装置ストッパーピン(L)	1
(9) Z041 ATTACHMENT FOR FIRST PROCESS OF WRAPPED-AROUND BUTTONS						根巻第一工程用アタッチメント
1		MAZ-041010A0	Wrapped-around button clamp asm.		根巻キボタンアタッチメント(組)	1
2		MAZ-04101000	Adjusting base		調節台	(1)
3		MAZ-04102000	Guide bar base		根巻案内棒台	(1)
4		SD-0630301-SP	Hinge screw D=6.35 H=3.0		根巻案内台段ネジ	(1)
5		MAZ-04103000	Guide bar, shank button width		根巻巾案内棒	(1)
6		SS-5080710-SP	Screw 1/8-44 L=6.5		根巻巾案内棒止ネジ	(1)
7		B2549-372-000	Screw		根巻案内棒台止ネジ	(1)
(10) Z044 ATTACHMENT FOR LABELS						ラベル付用アタッチメント
1		MAT-64401ZB0	Z044 asm.	A.3/76	Z044 (組)	1
1-1		MAT-64401ZA0	Clamp asm. for label		ラベル付クランプ(組)	(1)
2		MAT-61401Z00	Clamp for label		ラベル付クランプ	(1)
3		MAT-61402Z00	Clamp spring		クランプバネ	(1)
4		SS-5060310-SP	Screw 3/32-56 L=2.8		クランプバネ止ネジ	(2)
5		MAT-61403Z00	Stopper		ストッパー	(1)
6		MAZ-04404000	Feed plate		ラベル付用布押エ下板	(1)
7		B2542-372-000	Button clamp holder	A.3/76	ツマミ装置取付台	(1)
8		SS-9621413-SP	Screw 3/16-32 L=13.5	A.3/76	ツマミ足取付台止ネジ	(2)
9		B2546-372-000	Button clamp lifting hook	A.3/76	ツマミ装置引上げフック	(1)
10		SS-7150940-SP	Screw (A) 15/64-28 L=9.0	A.3/76	ツマミ装置引上げフック止ネジ(A)	(1)
11		SS-8150510-TP	Screw (B) 15/64-28 L=4.7	D.2/85	SS-7150940-SP	-
		SS-7150940-SP	Screw 15/64-28 L=9.0	A.2/85	ツマミ装置引上げフック止ネジ	(1)

15. ATTACHMENTS FOR SPECIAL ORDERS

When placing your orders for the following attachments, be sure to accompany the actual items with your orders.

1. ATTACHMENTS FOR MODEL MB-372

- (1) Z006 SHANK BUTTON (FOR SPECIAL USE) ATTACHMENT
This is used for special size button except Z003.
- (2) Z012 REINFORCING-STAY BUTTON ATTACHMENT FOR METAL BUTTON
This is used in common with Z003.

2. ATTACHMENTS FOR MODEL MB-373

- (1) Z036 SHANK BUTTON (FOR SPECIAL USE) ATTACHMENT
This is used for special size button except Z033.
- (2) Z042 REINFORCING-STAY BUTTON ATTACHMENT FOR METAL BUTTON
This is used in common with Z038.

15. 特別注文用アタッチメント

下記のアタッチメントを御注文の際は、必ず現品をそえて御注文下さい。

1. MB-372用アタッチメント

- (1) Z006 柄付きボタン (特殊用) アタッチメント
Z003 以外の特殊サイズボタンに使用いたします。
- (2) Z012 金ボタン用力ボタンアタッチメント
Z008 と共用して使用いたします。

2. MB-373用アタッチメント

- (1) Z036 柄付きボタン (特殊用) アタッチメント
Z033 以外の特殊サイズボタンに使用いたします。
- (2) Z042 金ボタン用力ボタンアタッチメント
Z038 と共用して使用いたします。

